



TECHNICAL & SERVICE MANUAL

SANYO

SAP-K91GJA (X 2) + SAP-CM1621GA
SAP-K91GJA (X 2) + SAP-CM1821GA
SAP-K91GJA (X 2) + SAP-CM1821JA

FILE NO.

Destination: General (50Hz)
General (60Hz)

MULTI-SPLIT SYSTEM AIR CONDITIONER

Indoor Model No	Product Code No.
SAP-K91GJA-S	1 852 070 37
SAP-K91GJA-S	1 852 070 37
SAP-K91GJA-S	1 852 070 37

Outdoor Model No.	Product Code No.
SAP-CM1621GA-S	1 852 071 48
SAP-CM1821GA-S	1 852 071 49
SAP-CM1821JA-S	1 852 071 50

Indoor Unit

Outdoor Unit

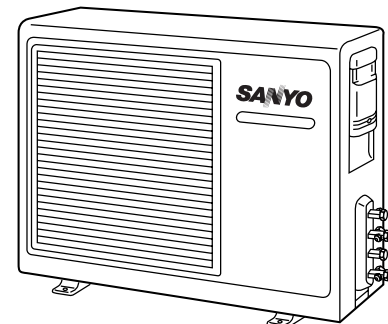
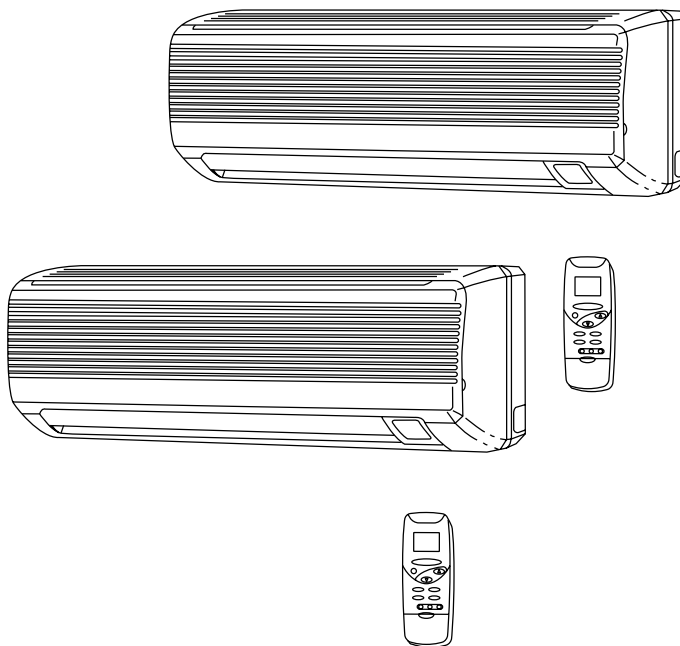

SAP-CM1621GA
SAP-CM1821GA
SAP-CM1821JA

SAP-K91GJA (X2)
SAP-K91GJA (X2)
SAP-K91GJA (X2)



Большая библиотека технической документации

<https://splitsystema48.ru/instrukcii-po-ekspluatácii-kondicionerov.html>

каталоги, инструкции, сервисные мануалы, схемы.

IMPORTANT!

Please Read Before Starting

This air conditioning system meets strict safety and operating standards. As the installer or service person, it is an important part of your job to install or service the system so it operates safely and efficiently.

For safe installation and trouble-free operation, you must:

- Carefully read this instruction booklet before beginning.
- Follow each installation or repair step exactly as shown.
- Observe all local, state, and national electrical codes.
- Pay close attention to all warning and caution notices given in this manual.



WARNING

This symbol refers to a hazard or unsafe practice which can result in severe personal injury or death.



CAUTION

This symbol refers to a hazard or unsafe practice which can result in personal injury or product or property damage.

If Necessary, Get Help

These instructions are all you need for most installation sites and maintenance conditions. If you require help for a special problem, contact our sales/service outlet or your certified dealer for additional instructions.

In Case of Improper Installation

The manufacturer shall in no way be responsible for improper installation or maintenance service, including failure to follow the instructions in this document.

SPECIAL PRECAUTIONS

WARNING When Wiring



ELECTRICAL SHOCK CAN CAUSE SEVERE PERSONAL INJURY OR DEATH. ONLY A QUALIFIED, EXPERIENCED ELECTRICIAN SHOULD ATTEMPT TO WIRE THIS SYSTEM.

- Do not supply power to the unit until all wiring and tubing are completed or reconnected and checked.
- Highly dangerous electrical voltages are used in this system. Carefully refer to the wiring diagram and these instructions when wiring. Improper connections and inadequate grounding can cause **accidental injury or death**.
- **Ground the unit** following local electrical codes.
- Connect all wiring tightly. Loose wiring may cause overheating at connection points and a possible fire hazard.

When Transporting

Be careful when picking up and moving the indoor and outdoor units. Get a partner to help, and bend your knees when lifting to reduce strain on your back. Sharp edges or thin aluminum fins on the air conditioner can cut your fingers.

When Installing...

...In a Ceiling or Wall

Make sure the ceiling/wall is strong enough to hold the unit's weight. It may be necessary to construct a strong wood or metal frame to provide added support.

...In a Room

Properly insulate any tubing run inside a room to prevent "sweating" that can cause dripping and water damage to walls and floors.

...In Moist or Uneven Locations

Use a raised concrete pad or concrete blocks to provide a solid, level foundation for the outdoor unit. This prevents water damage and abnormal vibration.

...In an Area with High Winds

Securely anchor the outdoor unit down with bolts and a metal frame. Provide a suitable air baffle.

...In a Snowy Area (for Heat Pump-type Systems)

Install the outdoor unit on a raised platform that is higher than drifting snow. Provide snow vents.

When Connecting Refrigerant Tubing

- Use the flare method for connecting tubing.
- Apply refrigerant lubricant to the matching surfaces of the flare and union tubes before connecting them, then tighten the nut with a torque wrench for a leak-free connection.
- Check carefully for leaks before starting the test run.

When Servicing

- Turn the power OFF at the main power box (mains) before opening the unit to check or repair electrical parts and wiring.
- Keep your fingers and clothing away from any moving parts.
- Clean up the site after you finish, remembering to check that no metal scraps or bits of wiring have been left inside the unit being serviced.

Others



CAUTION

- Ventilate any enclosed areas when installing or testing the refrigeration system. Escaped refrigerant gas, on contact with fire or heat, can produce dangerously toxic gas.
- Confirm upon completing installation that no refrigerant gas is leaking. If escaped gas comes in contact with a stove, gas water heater, electric room heater or other heat source, it can produce dangerously toxic gas.

Table of Contents

	Page
■ Unit Combination	iii
1. OPERATING RANGE	1
2. SPECIFICATIONS	
2-1. Unit Specifications	2
2-2. Major Component Specifications	5
2-3. Other Component Specifications	9
3. DIMENSIONAL DATA	10
4. COOLING CAPACITY	12
5. AIR THROW DISTANCE CHART	18
6. REFRIGERANT FLOW DIAGRAM	19
7. ELECTRICAL DATA	
7-1. Electrical Characteristics	20
7-2. Electric Wiring Diagrams	23
8. INSTALLATION INSTRUCTIONS	
8-1. Installation Site Selection	25
8-2. Remote Control Unit Installation Position	27
8-3. Recommended Wire Length and Diameter	28
9. FUNCTION	
9-1. Room Temperature Control	29
9-2. Dry Operation	30
9-3. Freeze Prevention	30
10. TROUBLESHOOTING	
10-1. Check before and after troubleshooting	31
10-2. Air conditioner does not operate	32
10-3. Some part of air conditioner does not operate	37
10-4. Air conditioner operates, but abnormalities are observed	39
10-5. If a sensor is defective	40
11. ARRANGEMENT OF ELECTRICAL COMPONENT	41
12. CHECKING ELECTRICAL COMPONENTS	
12-1. Measurement of Insulation Resistance	42
12-2. Checking Continuity of Fuse on PCB Ass'y	43
12-3. Checking Motor Capacitor	43
13. MAINTENANCE	
13-1. Changing Address of Remote Control Unit in Indoor Unit	44

■ Unit Combination

Combine indoor and outdoor units only as listed below.

Outdoor Unit	Indoor Unit	Symbol of Indoor Unit	Refer to
SAP-CM1621GA	K91GJA	A	Fig.1
	K91GJA	B	
SAP-CM1821G	K91GJA	A	Fig.1
	K91GJA	B	
SAP-CM1821JA	K91GJA	A	Fig.1
	K91GJA	B	

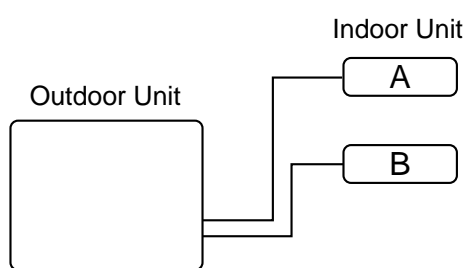

Fig.1

1. OPERATING RANGE

	Temperature	Indoor Air Intake Temp.	Outdoor Air Intake Temp.
Cooling	Maximum	32°C D.B. / 23°C W.B.	43°C D.B.
	Minimum	19°C D.B. / 14°C W.B.	19°C D.B.

2. SPECIFICATIONS

2-1. Unit Specifications

Indoor Unit **SAP-K91GJA**
Outdoor Unit **SAP-CM1621GA**

No. of indoor units.		1-unit		2-units		
Power Source		220 / 230 / 240 V		Single phase 50 Hz		
Performance	Cooling					
	Capacity	kW	2.30		4.60	
		BTU/h	7,800		15,700	
	Air circulation (High)	m ³ /h	430		430 X2	
Moisture removal (High)	Liters/h	0.8		0.8X2		
Electrical Rating	Voltage rating	V	220 / 230 / 240			
	Available voltage range	V	198 to 264			
	Running amperes	A	3.5 / 3.5 / 3.5		6.5 / 6.5 / 6.5	
	Power input	W	750 / 780 / 800		1,410 / 1,450 / 1,500	
	Power factor	%	97 / 97 / 95		99 / 97 / 96	
	C.O.P.	W/W	3.1 / 2.9 / 2.9		3.3 / 3.2 / 3.1	
	Compressor locked rotor amperes	A	17 / 18 / 19		34 / 36 / 38	
Features	Controls / Temperature control		Microprocessor / I.C. thermostat			
	Control unit		Wireless remote control unit			
	Timer		1-hour OFF / 12-hour ON or OFF			
	Fan speeds	Indoor / Outdoor	3 and Auto / 1 (Hi)			
	Airflow direction (Indoor)	Horizontal	Manual			
		Vertical	Auto			
	Air filter		Washable, Anti-Mold			
	Compressor		Rotary (Hermetic)			
	Refrigerant / Amount charged at shipment		g	R22 / 1,320 (660X2)		
	Refrigerant control		Capillary tube			
	Operation sound	Indoor – Hi / Me / Lo	dB-A	39 / 37 / 33		
		Outdoor – Hi	dB-A	53		
	Refrigerant tubing connections		Flare type			
	Max. allowable tubing length at shipment		m	7.5		
	Refrigerant tube diameter	Narrow tube	mm (in.)	6.35 (1/4)		
Wide tube		mm (in.)	9.52 (3/8)			
Refrigerant tube kit / Accessories		Optional / Hanging wall bracket				
Dimensions & Weight	Unit dimensions		Indoor Unit		Outdoor Unit	
			Height	mm	250	630
			Width	mm	790	810
	Package dimensions		Depth	mm	174	275
			Height	mm	242	704
			Width	mm	850	953
	Weight	Depth	mm	312	369	
		Net	kg	7.0	48.0	
	Shipping		kg	10.0	52.5	
	Shipping volume		m ³	0.06	0.25	

DATA SUBJECT TO CHANGE WITHOUT NOTICE.

Remarks: Rating conditions are:
Indoor air temperature 27°C D.B. / 19°C W.B.
Outdoor air temperature 35°C D.B. / 24°C W.B.

Indoor Unit **SAP-K91GJA**
 Outdoor Unit **SAP-CM1821GA**

No. of indoor units.		1-unit		2-units		
Power Source		220 / 230 / 240 V		Single phase 50 Hz		
Performance	Cooling					
	Capacity	kW	2.60	5.20		
		BTU/h	8,900	17,700		
	Air circulation (High)	m ³ /h	430	430 X2		
	Moisture removal (High)	Liters/h	0.80	0.80X2		
Electrical Rating	Voltage rating	V	220 / 230 / 240			
	Available voltage range	V	198 to 264			
	Running amperes	A	4.6 / 4.8 / 5.0	8.5 / 8.5 / 9.0		
	Power input	W	960 / 1,000 / 1,060	1,840 / 1,880 / 2,000		
	Power factor	%	95 / 91 / 88	98 / 96 / 93		
	C.O.P.	W/W	2.7 / 2.6 / 2.5	2.8 / 2.8 / 2.6		
	Compressor locked rotor amperes	A	22 / 23 / 24	44 / 46 / 48		
Features	Controls / Temperature control		Microprocessor / I.C. thermostat			
	Control unit		Wireless remote control unit			
	Timer		1-hour OFF / 12-hour ON or OFF			
	Fan speeds	Indoor / Outdoor	3 and Auto / 1 (Hi)			
	Airflow direction (Indoor)	Horizontal	Manual			
		Vertical	Auto			
	Air filter		Washable, Anti-Mold			
	Compressor		Rotary (Hermetic)			
	Refrigerant / Amount charged at shipment	g	R22 / 1,260 (630X2)			
	Refrigerant control		Capillary tube			
	Operation sound	Indoor – Hi / Me / Lo	dB-A	39 / 37 / 33		
		Outdoor – Hi	dB-A	53		
	Refrigerant tubing connections		Flare type			
	Max. allowable tubing length at shipment	m	7.5			
	Refrigerant tube diameter	Narrow tube	mm (in.)	6.35 (1/4)		
Wide tube		mm (in.)	9.52 (3/8)			
Refrigerant tube kit / Accessories		Optional / Hanging wall bracket				
Dimensions & Weight			Indoor Unit	Outdoor Unit		
	Unit dimensions	Height	mm	250	630	
		Width	mm	790	810	
		Depth	mm	174	275	
	Package dimensions	Height	mm	242	704	
		Width	mm	850	953	
		Depth	mm	312	369	
	Weight	Net	kg	7.0	48.0	
		Shipping	kg	10.0	52.5	
	Shipping volume	m ³		0.06	0.25	

DATA SUBJECT TO CHANGE WITHOUT NOTICE.

Remarks: Rating conditions are:
 Indoor air temperature 27°C D.B. / 19°C W.B.
 Outdoor air temperature 35°C D.B. / 24°C W.B.

Indoor Unit **SAP-K91GJA**
 Outdoor Unit **SAP-CM1821JA**

No. of indoor units.				1-unit	2-units
Power Source				220V Single phase 60 Hz	
Performance	Cooling				
	Capacity		kW	2.60	5.20
			BTU/h	8,900	17,700
	Air circulation (High)		m ³ /h	430	430X2
	Moisture removal (High)		Liters/h	0.85	0.85X2
Electrical Rating	Voltage rating			V 220	
	Available voltage range			V 198 to 242	
	Running amperes			A 4.6	8.5
	Power input			W 960	1,840
	Power factor			% 95	98
	C.O.P.			W/W 2.7	2.8
	Compressor locked rotor amperes			A 24	48
Features	Controls / Temperature control			Microprocessor / I.C. thermostat	
	Control unit			Wireless remote control unit	
	Timer			1-hour OFF / 12-hour ON or OFF	
	Fan speeds			Indoor / Outdoor 3 and Auto / 1 (Hi)	
	Airflow direction (Indoor)			Horizontal Manual	
				Vertical Auto	
	Air filter			Washable, Anti-Mold	
	Compressor			Rotary (Hermetic)	
	Refrigerant / Amount charged at shipment			g R22 / 1,320 (660X2)	
	Refrigerant control			Capillary tube	
	Operation sound			Indoor – Hi / Me / Lo dB-A 39 / 37 / 33	
				Outdoor – Hi dB-A 53	
	Refrigerant tubing connections			Flare type	
	Max. allowable tubing length at shipment			m 7.5	
	Refrigerant tube diameter			Narrow tube mm (in.) 6.35 (1/4)	
			Wide tube mm (in.) 9.52 (3/8)		
Refrigerant tube kit / Accessories			Optional / Hanging wall bracket		
Dimensions & Weight				Indoor Unit	Outdoor Unit
	Unit dimensions		Height	mm 250	630
			Width	mm 790	810
			Depth	mm 174	275
	Package dimensions		Height	mm 242	704
			Width	mm 850	953
			Depth	mm 312	369
	Weight		Net	kg 7.0	48.0
			Shipping	kg 10.0	52.5
	Shipping volume			m ³ 0.06	0.25

DATA SUBJECT TO CHANGE WITHOUT NOTICE.

Remarks: Rating conditions are:
 Indoor air temperature 27°C D.B. / 19°C W.B.
 Outdoor air temperature 35°C D.B. / 24°C W.B.

2-2. Major Component Specifications

2-2-1. Indoor Unit

Indoor Unit **SAP-K91GJA**

Controller PCB	Part No.		POW-K91GJA		
	Controls		Microprocessor		
	Control circuit fuse		250 V – 3.15 A		
Remote Control Unit			RCS-2S2E		
Fan & Fan Motor	Type		Cross-flow		
	Number ... Dia. and length		mm	1 ... ø95 / L578	
	Fan motor model ... Number		IBH-884-020 ... 1		
	No. of poles ...50/60Hz rpm (High)		2 ... 1,280/1,280		
	Nominal output		W	20	
	Coil resistance (Ambient temp. 20°C)		Ω	WHT – BRN : 201 WHT – VLT : 261	
	Safety devices	Type	Thermal fuse		
		Operating temp.	Open	°C	130
	Run capacitor		Close	—	
				μF	1.5
Flap Motor			VAC	440	
	Type	Stepping motor			
Model		MP24GA3			
Rating		DC 12 V			
Coil resistance (Ambient temp. 25°C)		Ω	A pair of each terminal: 380 ± 7%		
Heat Exch. Coil	Coil		Aluminum plate fin / Copper tube		
	Rows		2		
	Fin pitch		mm	1.4	
	Face area		m ²	0.110	

DATA SUBJECT TO CHANGE WITHOUT NOTICE.

2-2-2. Outdoor Unit

Outdoor Unit **SAP-CM1621GA**

Compressor	Type		Rotary (Hermetic)			
	Compressor model ... Number		C-1R71H5U ... 2 / 80688745-S ... 2			
	Nominal output		W	700		
	Compressor oil ... Amount		cc	4GSD-T or SAY-56T ... 320X2		
	Coil resistance (Ambient temp. 25°C)		Ω	C - R : 4.57 C - S : 6.90		
	Safety devices	Type		External protector (OLR 1, 3)	External protector (OLR 2, 4)	
		Overload relay ... Number		MRA98782-9201 ... 2	CS-7C115 ... 2	
		Operating temp.	Open	°C	130 ± 5	115 ± 3
			Close	°C	69 ± 11	95 ± 5
	Operating amp. (Ambient temp. 25°C)		Trip in 6 to 16 sec. at 13.5A		—	
Run capacitor ... Number		μF	20.0 ... 2			
		VAC	400 ... 2			
Fan & Fan Motor	Type		Propeller			
	Number ... Dia.		mm	1 ... ø420		
	Fan motor model ... Number		KFG6-51C5P-S ... 1			
	No. of poles ... rpm (230 V)		6 ... 870			
	Nominal output		W	50		
	Coil resistance (Ambient temp. 20°C)		Ω	WHT - BRN : 67.1 WHT - YEL : 83.8		
	Safety devices	Type		Thermal protector		
		Operating temp.	Open	°C	130 ± 8	
	Close				Automatic reclosing	
	Run capacitor		μF	4.0		
		VAC	440			
Heat Exch. Coil	Coil		Aluminum plate fin / Copper tube			
	Rows		1			
	Fin pitch		mm	1.3		
	Face area		m ²	0.506		
External Finish		Acrylic baked-on enamel finish				

DATA SUBJECT TO CHANGE WITHOUT NOTICE.

Outdoor Unit **SAP-CM1821GA**

Compressor	Type		Rotary (Hermetic)			
	Compressor model ... Number		C-1R80H5K ... 2 / 80603345-S ... 2			
	Nominal output		W	800		
	Compressor oil ... Amount		cc	4GSD-T or SAY-56T ... 320X2		
	Coil resistance (Ambient temp. 25°C)		Ω	C - R : 3.65 C - S : 5.38		
	Safety devices	Type		External protector (OLR 1, 3)	External protector (OLR 2, 4)	
		Overload relay ... Number		MRA99109-9201 ... 2	CS-7C115 ... 2	
		Operating temp.	Open	°C	150 ± 5	115 ± 3
			Close	°C	69 ± 11	95 ± 5
	Operating amp. (Ambient temp. 25°C)		Trip in 6 to 16 sec. at 16A		—	
Run capacitor ... Number		μF	30.0 ... 2			
		VAC	400 ... 2			
Fan & Fan Motor	Type		Propeller			
	Number ... Dia.		mm	1 ... ø420		
	Fan motor model ... Number		KFG6-51C5P-S ... 1			
	No. of poles ... rpm (230 V)		6 ... 870			
	Nominal output		W	50		
	Coil resistance (Ambient temp. 20°C)		Ω	WHT - BRN : 67.1 WHT - YEL : 83.8		
	Safety devices	Type		Thermal protector		
		Operating temp.	Open	°C	130 ± 8	
	Close			Automatic reclosing		
	Run capacitor		μF	4.0		
VAC			440			
Heat Exch. Coil	Coil		Aluminum plate fin / Copper tube			
	Rows		1			
	Fin pitch		mm	1.3		
	Face area		m ²	0.506		
External Finish			Acrylic baked-on enamel finish			

DATA SUBJECT TO CHANGE WITHOUT NOTICE.

Outdoor Unit **SAP-CM1821JA**

Compressor	Type		Rotary (Hermetic)			
	Compressor model ... Number		C-1R71H6U ... 2 / 80688746-S ... 2			
	Nominal output		W	700		
	Compressor oil ... Amount		cc	4GSD-T or SAY-56T ... 320X2		
	Coil resistance (Ambient temp. 25°C)		Ω	C - R : 2.87 C - S : 3.29		
	Safety devices	Type		External protector (OLR 1, 3)	External protector (OLR 2, 4)	
		Overload relay ... Number		MRA99053-9201 ... 2	CS-7C115 ... 2	
		Operating temp.	Open	°C	145 ± 5	115 ± 3
			Close	°C	69 ± 11	95 ± 5
	Operating amp. (Ambient temp. 25°C)		Trip in 6 to 16 sec. at 16.5A		—	
Run capacitor ... Number		μF	25.0 ... 2			
		VAC	400 ... 2			
Fan & Fan Motor	Type		Propeller			
	Number ... Dia.		mm	1 ... ø420		
	Fan motor model ... Number		KFG6-51C6P-S ... 1			
	No. of poles ... rpm (220 V)		6 ... 870			
	Nominal output		W	50		
	Coil resistance (Ambient temp. 20°C)		Ω	WHT - BRN : 81.3 WHT - PNK : 97.0		
	Safety devices	Type		Thermal protector		
		Operating temp.	Open	°C	130 ± 5	
	Close			Automatic reclosing		
	Run capacitor		μF	3.0		
VAC			440			
Heat Exch. Coil	Coil		Aluminum plate fin / Copper tube			
	Rows		1			
	Fin pitch		mm	1.3		
	Face area		m ²	0.506		
External Finish		Acrylic baked-on enamel finish				

DATA SUBJECT TO CHANGE WITHOUT NOTICE.

2-3. Other Component Specifications

Indoor Unit **SAP-K91GJA**

Transformer (TR)		ATR-J105	
Rating	Primary	AC 230V, 50/60Hz	
	Secondary	19V, 0.526A	
	Capacity	10VA	
Coil resistance	Ω (at 21°C)	Primary (WHT – WHT):	205 \pm 10%
		Secondary (BRN – BRN):	2.0 \pm 10%
Thermal cut-off temp.		150°C	

Thermistor (Coil sensor)		DTN-TKS131B	
Resistance	k Ω	0°C	15.0 \pm 2%

Thermistor (Room sensor)		DTN-TKS128B	
Resistance	k Ω	25°C	5.0 \pm 3%

Outdoor Unit **SAP-CM1621GA**
SAP-CM1821GA
SAP-CM1821JA

Power Relay (PR)		G7L-2A-TUB-55	
Coil rating		AC 200–240V, 50/60Hz	
Coil resistance	Ω (at 23°C)	21 \pm 15%	
Contact rating		AC 220V, 25A	

3. DIMENSIONAL DATA

Indoor Unit **SAP-K91GJA**

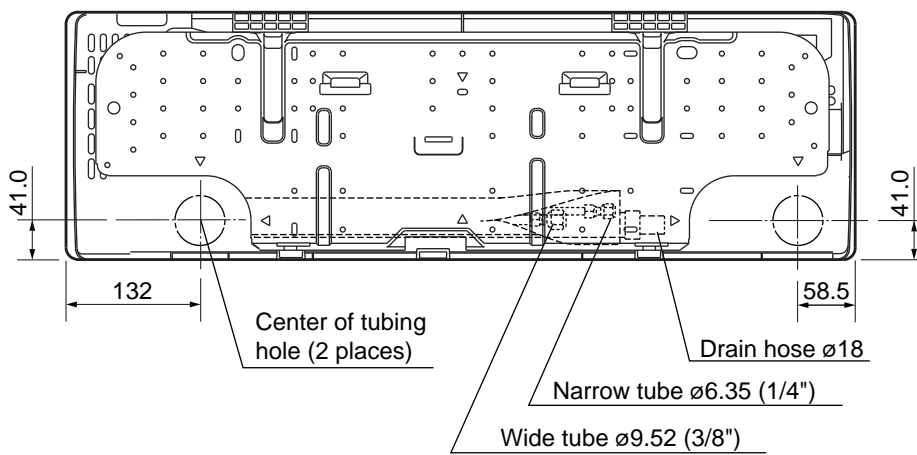
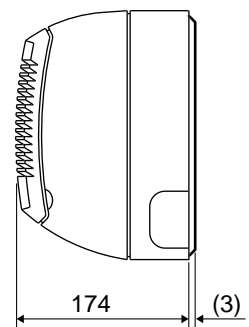
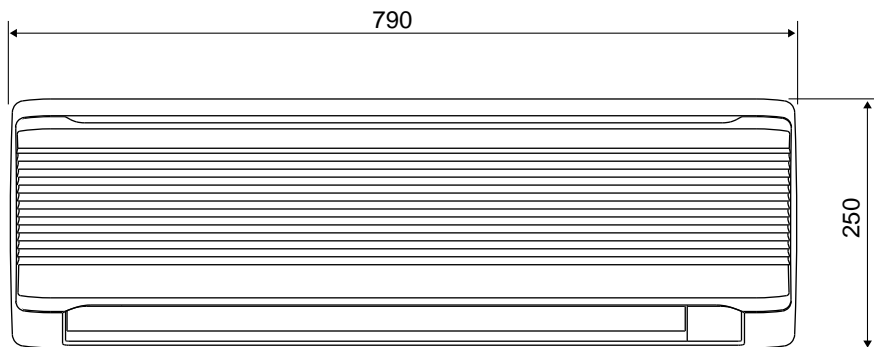
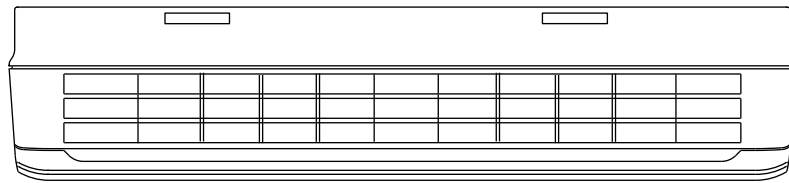

Remote control unit

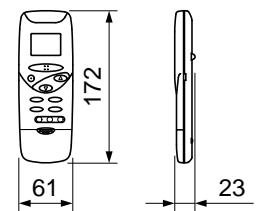

Unit : mm

Outdoor Unit **SAP-CM1621GA**
SAP-CM1821GA
SAP-CM1821JA

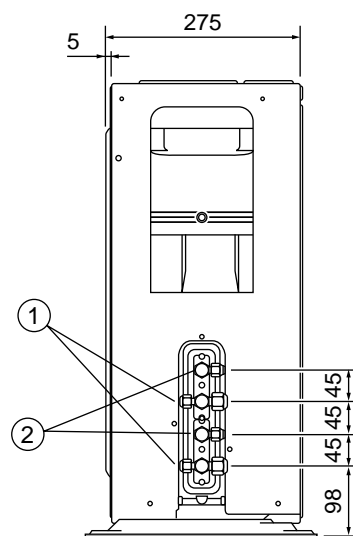
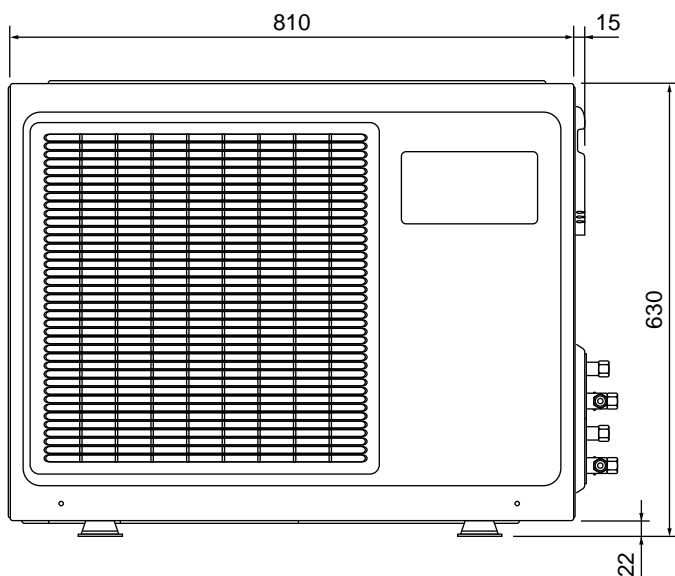
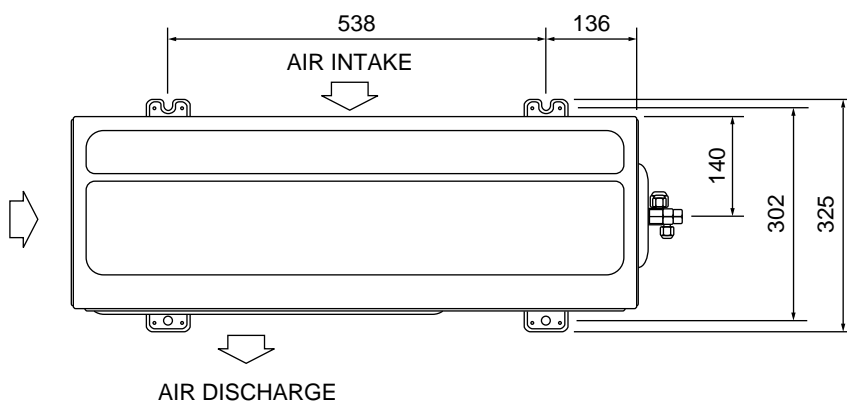

- ① Wide tube service valve
ø9.52 (3/8")
- ② Narrow tube service valve
ø6.35 (1/4")

Unit : mm

4. COOLING CAPACITY

■ 1 - indoor unit in operation A(or B)

Indoor Unit **SAP-K91GJA (X1)**

Outdoor Unit **SAP-CM1621GA**

230 V Single phase 50 Hz

NOTE

A : SAP-K91GJA

B : SAP-K91GJA

RATING CAPACITY		2.30 kW						
EVAPORATOR		CONDENSER						
ENT. TEMP. °C		OUTDOOR AMBIENT TEMP. °C						
W.B.	D.B.		20	25	30	35	40	43
15		TC	2.32	2.22	2.12	2.02	1.89	1.74
		CM	0.48	0.52	0.55	0.60	0.66	0.73
	21	SHC	1.60	1.55	1.50	1.46	1.40	1.33
	23	SHC	1.81	1.76	1.71	1.67	1.61	1.54
	25	SHC	2.02	1.97	1.92	1.88	1.82	1.74
	27	SHC	2.23	2.18	2.12	2.02	1.89	1.74
	29	SHC	2.32	2.22	2.12	2.02	1.89	1.74
	31	SHC	2.32	2.22	2.12	2.02	1.89	1.74
17		TC	2.49	2.38	2.27	2.16	2.03	1.87
		CM	0.49	0.53	0.57	0.61	0.68	0.75
	21	SHC	1.39	1.34	1.29	1.24	1.18	1.11
	23	SHC	1.60	1.55	1.50	1.45	1.39	1.32
	25	SHC	1.81	1.76	1.71	1.66	1.60	1.53
	27	SHC	2.02	1.97	1.92	1.87	1.81	1.74
	29	SHC	2.23	2.18	2.13	2.08	2.02	1.87
	31	SHC	2.44	2.38	2.27	2.16	2.03	1.87
19		TC	2.65	2.53	2.42	# 2.30	2.16	1.99
		CM	0.51	0.55	0.59	0.63	0.70	0.77
	21	SHC	1.16	1.11	1.06	1.02	0.96	0.89
	23	SHC	1.37	1.32	1.27	1.23	1.17	1.10
	25	SHC	1.58	1.53	1.48	1.43	1.38	1.31
	27	SHC	1.79	1.74	1.69	1.64	1.59	1.52
	29	SHC	2.00	1.95	1.90	1.85	1.80	1.73
	31	SHC	2.21	2.16	2.11	2.06	2.01	1.94
21		TC	2.80	2.68	2.56	2.44	2.29	2.11
		CM	0.52	0.56	0.60	0.65	0.72	0.79
	23	SHC	1.14	1.10	1.05	1.00	0.94	0.87
	25	SHC	1.35	1.31	1.26	1.21	1.15	1.08
	27	SHC	1.56	1.51	1.47	1.42	1.36	1.29
	29	SHC	1.77	1.72	1.68	1.63	1.57	1.50
	31	SHC	1.98	1.93	1.89	1.84	1.78	1.71
23		TC	2.98	2.85	2.71	2.56	2.40	2.23
		CM	0.53	0.58	0.62	0.67	0.74	0.81
	25	SHC	1.11	1.07	1.02	0.96	0.90	0.85
	27	SHC	1.32	1.28	1.23	1.17	1.11	1.06
	29	SHC	1.53	1.49	1.44	1.38	1.32	1.27
	31	SHC	1.74	1.70	1.65	1.59	1.53	1.48

TC : Total Cooling Capacity (kW)

SHC : Sensible Heat Capacity (kW)

CM : Compressor Input (kW)

Rating conditions (#Mark) are

Outdoor Ambient Temp. 35°C D.B.

Indoor Unit Entering Air Temp. 27°C D.B. / 19°C W.B.

■ 2 - indoor units in operation A + B

Indoor Unit **SAP-K91GJA (X2)**
 Outdoor Unit **SAP-CM1621GA**

230 V Single phase 50 Hz

NOTE

A : SAP-K91GJA
 B : SAP-K91GJA

RATING CAPACITY		4.60 kW						
EVAPORATOR		CONDENSER						
ENT. TEMP. °C		OUTDOOR AMBIENT TEMP. °C						
W.B.	D.B.		20	25	30	35	40	43
15		TC	4.63	4.43	4.23	4.03	3.78	3.49
		CM	0.96	1.04	1.11	1.19	1.28	1.38
	21	SHC	3.21	3.11	3.01	2.91	2.79	2.65
	23	SHC	3.63	3.53	3.43	3.33	3.21	3.07
	25	SHC	4.05	3.95	3.85	3.75	3.63	3.49
	27	SHC	4.47	4.37	4.23	4.03	3.78	3.49
	29	SHC	4.63	4.43	4.23	4.03	3.78	3.49
17		TC	4.97	4.76	4.54	4.32	4.06	3.74
		CM	0.99	1.07	1.14	1.23	1.32	1.41
	21	SHC	2.78	2.68	2.58	2.48	2.36	2.22
	23	SHC	3.20	3.10	3.00	2.90	2.78	2.64
	25	SHC	3.62	3.52	3.42	3.32	3.20	3.06
	27	SHC	4.04	3.94	3.84	3.74	3.62	3.48
	29	SHC	4.46	4.35	4.26	4.16	4.04	3.74
19		TC	5.29	5.06	4.83	# 4.60	4.32	3.98
		CM	1.02	1.10	1.18	1.26	1.36	1.46
	21	SHC	2.33	2.23	2.13	2.03	1.92	1.78
	23	SHC	2.75	2.65	2.55	2.45	2.34	2.20
	25	SHC	3.17	3.07	2.97	2.87	2.76	2.62
	27	SHC	3.59	3.48	3.39	3.29	3.18	3.04
	29	SHC	4.00	3.90	3.81	3.71	3.59	3.45
21		TC	5.61	5.36	5.12	4.88	4.58	4.22
		CM	1.05	1.13	1.21	1.30	1.40	1.50
	23	SHC	2.29	2.19	2.09	2.00	1.89	1.75
	25	SHC	2.71	2.61	2.51	2.42	2.31	2.17
	27	SHC	3.13	3.03	2.93	2.84	2.73	2.59
	29	SHC	3.55	3.45	3.35	3.26	3.14	3.01
	31	SHC	3.97	3.87	3.77	3.68	3.56	3.43
23		TC	5.95	5.69	5.42	5.12	4.79	4.46
		CM	1.07	1.16	1.24	1.33	1.43	1.53
	25	SHC	2.23	2.13	2.03	1.93	1.81	1.69
	27	SHC	2.65	2.55	2.45	2.34	2.23	2.11
	29	SHC	3.07	2.97	2.87	2.76	2.65	2.53
	31	SHC	3.49	3.39	3.29	3.18	3.07	2.95

TC : Total Cooling Capacity (kW)

SHC : Sensible Heat Capacity (kW)

CM : Compressor Input (kW)

Rating conditions (#Mark) are

Outdoor Ambient Temp. 35°C D.B.

Indoor Unit Entering Air Temp. 27°C D.B. / 19°C W.B.

■ 1 - indoor unit in operation A(or B)

Indoor Unit **SAP-K91GJA (X1)**
 Outdoor Unit **SAP-CM1821GA**

230 V Single phase 50 Hz

NOTE

A : SAP-K91GJA
 B : SAP-K91GJA

RATING CAPACITY		2.60 kW						
EVAPORATOR		CONDENSER						
ENT. TEMP. °C		OUTDOOR AMBIENT TEMP. °C						
W.B.	D.B.		20	25	30	35	40	43
15		TC	2.62	2.51	2.39	2.28	2.14	1.97
		CM	0.65	0.70	0.75	0.80	0.87	0.94
	21	SHC	1.76	1.70	1.64	1.58	1.52	1.43
	23	SHC	1.97	1.91	1.85	1.79	1.73	1.64
	25	SHC	2.18	2.12	2.06	2.00	1.94	1.85
	27	SHC	2.39	2.33	2.27	2.21	2.14	1.97
	29	SHC	2.60	2.51	2.39	2.28	2.14	1.97
17		TC	2.81	2.69	2.57	2.44	2.30	2.11
		CM	0.66	0.72	0.77	0.83	0.89	0.96
	21	SHC	1.55	1.49	1.43	1.37	1.30	1.22
	23	SHC	1.76	1.70	1.64	1.58	1.51	1.43
	25	SHC	1.97	1.91	1.85	1.79	1.72	1.64
	27	SHC	2.17	2.11	2.06	2.00	1.93	1.85
	29	SHC	2.38	2.32	2.27	2.21	2.14	2.06
19		TC	2.99	2.86	2.73	# 2.60	2.44	2.25
		CM	0.69	0.74	0.79	0.85	0.92	0.99
	21	SHC	1.32	1.26	1.20	1.14	1.08	0.99
	23	SHC	1.53	1.47	1.41	1.35	1.29	1.20
	25	SHC	1.74	1.68	1.62	1.56	1.50	1.41
	27	SHC	1.95	1.89	1.83	1.77	1.71	1.62
	29	SHC	2.16	2.10	2.04	1.98	1.92	1.83
21		TC	3.17	3.03	2.89	2.76	2.59	2.38
		CM	0.70	0.76	0.82	0.87	0.95	1.02
	23	SHC	1.30	1.24	1.18	1.13	1.06	0.98
	25	SHC	1.51	1.45	1.39	1.34	1.27	1.19
	27	SHC	1.72	1.66	1.60	1.54	1.48	1.40
	29	SHC	1.93	1.87	1.81	1.75	1.69	1.61
23		TC	3.36	3.22	3.07	2.89	2.71	2.52
		CM	0.72	0.78	0.84	0.90	0.97	1.04
	25	SHC	1.26	1.21	1.15	1.08	1.02	0.95
	27	SHC	1.47	1.42	1.36	1.29	1.23	1.16
	29	SHC	1.68	1.63	1.57	1.50	1.44	1.37
	31	SHC	1.89	1.84	1.78	1.71	1.65	1.58

TC : Total Cooling Capacity (kW)

SHC : Sensible Heat Capacity (kW)

CM : Compressor Input (kW)

Rating conditions (#Mark) are

Outdoor Ambient Temp. 35°C D.B.

Indoor Unit Entering Air Temp. 27°C D.B. / 19°C W.B.

■ 2 - indoor units in operation A + B

Indoor Unit **SAP-K91GJA (X2)**
 Outdoor Unit **SAP-CM1821GA**

230 V Single phase 50 Hz

NOTE

A : SAP-K91GJA
 B : SAP-K91GJA

RATING CAPACITY		5.20 kW						
EVAPORATOR		CONDENSER						
ENT. TEMP. °C		OUTDOOR AMBIENT TEMP. °C						
W.B.	D.B.		20	25	30	35	40	43
15		TC	5.24	5.01	4.78	4.56	4.28	3.94
		CM	1.29	1.39	1.49	1.60	1.79	2.00
	21	SHC	3.52	3.40	3.28	3.17	3.03	2.87
	23	SHC	3.94	3.82	3.70	3.59	3.45	3.29
	25	SHC	4.36	4.24	4.12	4.01	3.87	3.71
	27	SHC	4.78	4.66	4.54	4.43	4.28	3.94
	29	SHC	5.20	5.01	4.78	4.56	4.28	3.94
17		TC	5.62	5.38	5.13	4.89	4.59	4.23
		CM	1.32	1.43	1.53	1.64	1.84	2.04
	21	SHC	3.09	2.97	2.85	2.74	2.60	2.44
	23	SHC	3.51	3.39	3.27	3.16	3.02	2.86
	25	SHC	3.93	3.81	3.69	3.58	3.44	3.28
	27	SHC	4.35	4.23	4.11	4.00	3.86	3.69
	29	SHC	4.77	4.65	4.53	4.42	4.28	4.11
19		TC	5.98	5.72	5.46	# 5.20	4.89	4.50
		CM	1.36	1.47	1.58	1.69	1.90	2.10
	21	SHC	2.64	2.52	2.40	2.29	2.15	1.99
	23	SHC	3.06	2.94	2.82	2.71	2.57	2.41
	25	SHC	3.48	3.36	3.24	3.13	2.99	2.83
	27	SHC	3.90	3.78	3.66	3.55	3.41	3.25
	29	SHC	4.31	4.20	4.08	3.97	3.83	3.67
21		TC	6.34	6.06	5.79	5.51	5.18	4.77
		CM	1.40	1.52	1.62	1.74	1.95	2.15
	23	SHC	2.60	2.48	2.36	2.25	2.12	1.96
	25	SHC	3.01	2.90	2.78	2.67	2.54	2.38
	27	SHC	3.43	3.32	3.20	3.09	2.96	2.80
	29	SHC	3.85	3.74	3.62	3.51	3.38	3.22
	31	SHC	4.27	4.16	4.04	3.93	3.80	3.63
23		TC	6.73	6.44	6.13	5.79	5.42	5.04
		CM	1.43	1.56	1.67	1.79	2.00	2.21
	25	SHC	2.53	2.41	2.30	2.17	2.03	1.90
	27	SHC	2.95	2.83	2.72	2.59	2.45	2.32
	29	SHC	3.37	3.25	3.14	3.01	2.87	2.74
	31	SHC	3.79	3.67	3.55	3.43	3.29	3.15

TC : Total Cooling Capacity (kW)

SHC : Sensible Heat Capacity (kW)

CM : Compressor Input (kW)

Rating conditions (#Mark) are

Outdoor Ambient Temp. 35°C D.B.

Indoor Unit Entering Air Temp. 27°C D.B. / 19°C W.B.

■ 1 - indoor unit in operation A(or B)

Indoor Unit **SAP-K91GJA (X1)**

Outdoor Unit **SAP-CM1821JA**

220 V Single phase **60 Hz**

NOTE

A : SAP-K91GJA

B : SAP-K91GJA

RATING CAPACITY		2.60 kW						
EVAPORATOR		CONDENSER						
ENT. TEMP. °C		OUTDOOR AMBIENT TEMP. °C						
W.B.	D.B.		20	25	30	35	40	43
15		TC	2.62	2.51	2.39	2.28	2.14	1.97
		CM	0.62	0.67	0.72	0.77	0.85	0.92
	21	SHC	1.76	1.70	1.65	1.59	1.52	1.44
	23	SHC	1.97	1.91	1.85	1.80	1.73	1.65
	25	SHC	2.18	2.12	2.06	2.01	1.94	1.86
	27	SHC	2.39	2.33	2.27	2.22	2.14	1.97
	29	SHC	2.60	2.51	2.39	2.28	2.14	1.97
17		TC	2.81	2.69	2.57	2.44	2.30	2.11
		CM	0.64	0.69	0.74	0.79	0.87	0.95
	21	SHC	1.55	1.49	1.43	1.37	1.30	1.22
	23	SHC	1.76	1.70	1.64	1.58	1.51	1.43
	25	SHC	1.97	1.91	1.85	1.79	1.72	1.64
	27	SHC	2.18	2.12	2.06	2.00	1.93	1.85
	29	SHC	2.39	2.33	2.27	2.21	2.14	2.06
19		TC	2.99	2.86	2.73	# 2.60	2.44	2.25
		CM	0.66	0.71	0.76	0.82	0.89	0.97
	21	SHC	1.32	1.26	1.20	1.15	1.08	1.00
	23	SHC	1.53	1.47	1.41	1.36	1.29	1.21
	25	SHC	1.74	1.68	1.62	1.57	1.50	1.42
	27	SHC	1.95	1.89	1.83	1.78	1.71	1.63
	29	SHC	2.16	2.10	2.04	1.99	1.92	1.84
21		TC	3.17	3.03	2.89	2.76	2.59	2.38
		CM	0.67	0.73	0.78	0.84	0.92	1.00
	23	SHC	1.30	1.24	1.19	1.13	1.06	0.98
	25	SHC	1.51	1.45	1.39	1.34	1.27	1.19
	27	SHC	1.72	1.66	1.60	1.55	1.48	1.40
	29	SHC	1.93	1.87	1.81	1.76	1.69	1.61
23		TC	3.36	3.22	3.07	2.89	2.71	2.52
		CM	0.69	0.75	0.80	0.86	0.94	1.03
	25	SHC	1.27	1.21	1.15	1.09	1.02	0.95
	27	SHC	1.48	1.42	1.36	1.30	1.23	1.16
	29	SHC	1.69	1.63	1.57	1.51	1.44	1.37
	31	SHC	1.90	1.84	1.78	1.72	1.65	1.58

TC : Total Cooling Capacity (kW)

SHC : Sensible Heat Capacity (kW)

CM : Compressor Input (kW)

Rating conditions (#Mark) are

Outdoor Ambient Temp. 35°C D.B.

Indoor Unit Entering Air Temp. 27°C D.B. / 19°C W.B.

■ 2 - indoor units in operation A + B

Indoor Unit **SAP-K91GJA (X2)**

Outdoor Unit **SAP-CM1821JA**

220 V Single phase 60 Hz

NOTE

A : SAP-K91GJA

B : SAP-K91GJA

RATING CAPACITY			5.20 kW					
EVAPORATOR			CONDENSER					
ENT. TEMP. °C			OUTDOOR AMBIENT TEMP. °C					
W.B.	D.B.		20	25	30	35	40	43
15		TC	5.24	5.01	4.78	4.56	4.28	3.94
		CM	1.26	1.37	1.46	1.57	1.71	1.86
	21	SHC	3.53	3.41	3.29	3.18	3.04	2.87
	23	SHC	3.95	3.83	3.71	3.59	3.46	3.29
	25	SHC	4.36	4.25	4.13	4.01	3.88	3.71
	27	SHC	4.78	4.67	4.55	4.43	4.28	3.94
	29	SHC	5.20	5.01	4.78	4.56	4.28	3.94
17		TC	5.62	5.38	5.13	4.89	4.59	4.23
		CM	1.30	1.40	1.50	1.61	1.76	1.90
	21	SHC	3.10	2.98	2.86	2.74	2.61	2.44
	23	SHC	3.52	3.40	3.28	3.16	3.03	2.86
	25	SHC	3.94	3.82	3.70	3.58	3.45	3.28
	27	SHC	4.36	4.24	4.12	4.00	3.87	3.70
	29	SHC	4.78	4.66	4.54	4.42	4.29	4.12
19		TC	5.98	5.72	5.46	# 5.20	4.89	4.50
		CM	1.34	1.45	1.55	1.66	1.81	1.96
	21	SHC	2.64	2.52	2.41	2.29	2.16	2.00
	23	SHC	3.06	2.94	2.83	2.71	2.58	2.42
	25	SHC	3.48	3.36	3.25	3.13	3.00	2.83
	27	SHC	3.90	3.78	3.67	3.55	3.42	3.25
	29	SHC	4.32	4.20	4.09	3.97	3.84	3.67
21		TC	6.34	6.06	5.79	5.51	5.18	4.77
		CM	1.38	1.49	1.59	1.71	1.86	2.01
	23	SHC	2.60	2.49	2.37	2.26	2.13	1.96
	25	SHC	3.02	2.90	2.79	2.68	2.55	2.38
	27	SHC	3.44	3.32	3.21	3.10	2.96	2.80
	29	SHC	3.86	3.74	3.63	3.52	3.38	3.22
23		TC	6.73	6.44	6.13	5.79	5.42	5.04
		CM	1.40	1.53	1.64	1.76	1.91	2.07
	25	SHC	2.53	2.42	2.30	2.18	2.04	1.90
	27	SHC	2.95	2.84	2.72	2.59	2.46	2.32
	29	SHC	3.37	3.26	3.14	3.01	2.88	2.74
	31	SHC	3.79	3.68	3.56	3.43	3.30	3.16

TC : Total Cooling Capacity (kW)

SHC : Sensible Heat Capacity (kW)

CM : Compressor Input (kW)

Rating conditions (#Mark) are

Outdoor Ambient Temp. 35°C D.B.

Indoor Unit Entering Air Temp. 27°C D.B. / 19°C W.B.

5. AIR THROW DISTANCE CHART

Indoor Unit SAP-K91GJA

Room air temp. : 27°C

Fan speed : High

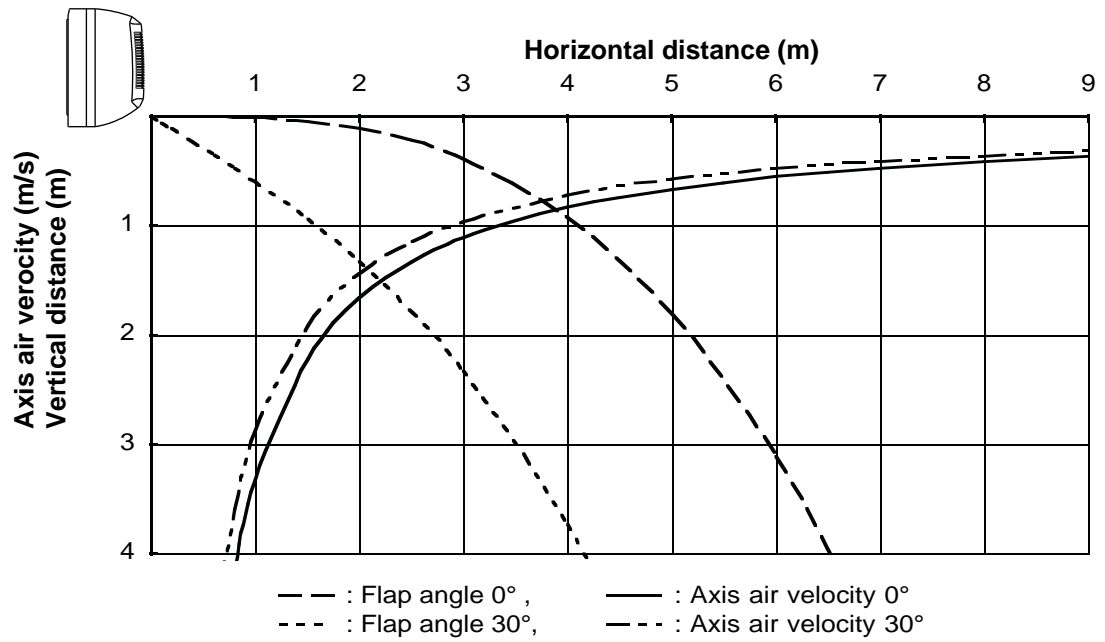

6. REFRIGERANT FLOW DIAGRAM

Indoor Unit	SAP-K91GJA (X2)	SAP-K91GJA (X2)	SAP-K91GJA (X2)
Outdoor Unit	SAP-CM1621GA	SAP-CM1821GA	SAP-CM1821JA

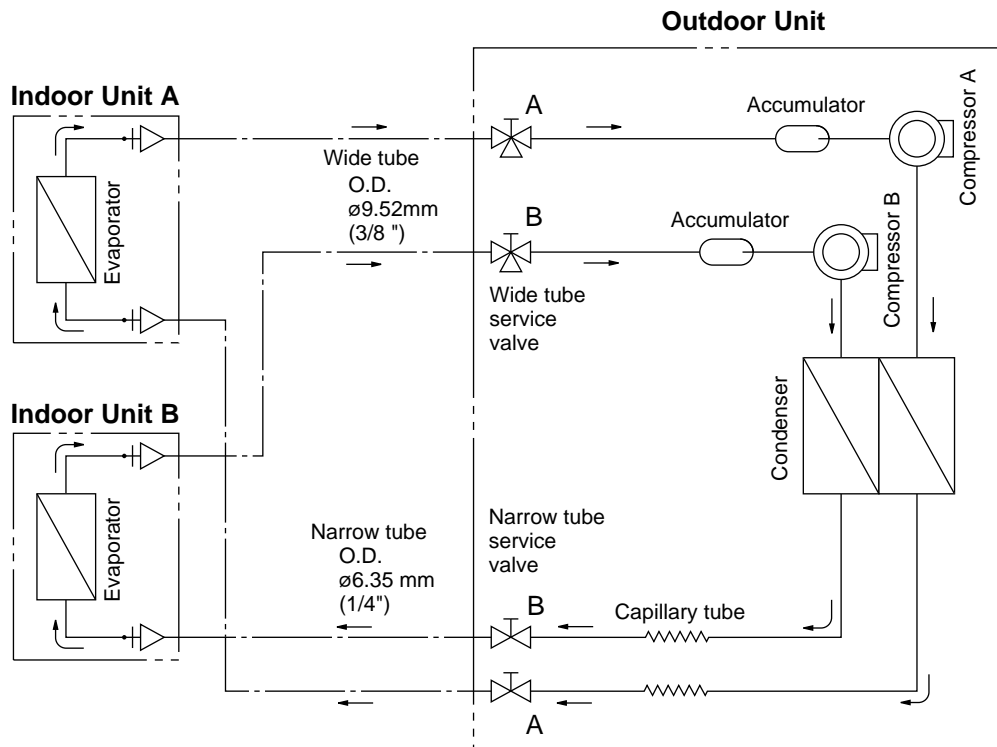

Insulation of Refrigerant Tubing

IMPORTANT

Because capillary tubing is used in the outdoor unit, both the wide and narrow tubes of this air conditioner become cold. To prevent heat loss and wet floors due to dripping of condensation, **both tubes must be well insulated** with a proper insulation material. The thickness of the insulation should be a min. 8 mm.

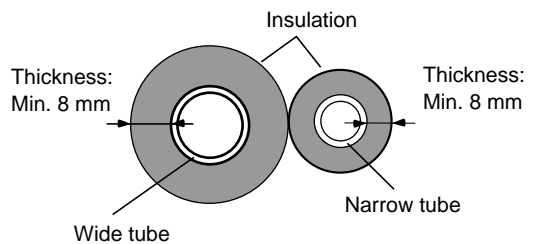

CAUTION

After a tube has been insulated, never try to bend it into a narrow curve because it can cause the tube to break or crack.

7. ELECTRICAL DATA

7-1. Electrical Characteristics

Indoor Unit **SAP-K91GJA (X1)**

Outdoor Unit **SAP-CM1621GA**

		Indoor Unit		Outdoor Unit		Complete Unit
		Fan Motor		Fan Motor	Compressor	
Performance at		230V Single phase 50Hz				
Rating Conditions	Running Amps.	A	0.18	0.49	2.83	3.5
	Power Input	kW	0.037	0.112	0.631	0.78
Full Load Conditions	Running Amps.	A	0.18	0.49	3.63	4.3
	Power Input	kW	0.037	0.112	0.811	0.96

Rating Conditions : Indoor Air Temperature 27°C D.B. / 19°C W.B.
Outdoor Air Temperature 35°C D.B.

Full Load Conditions : Indoor Air Temperature 32°C D.B. / 23°C W.B.
Outdoor Air Temperature 43°C D.B.

Indoor Unit **SAP-K91GA (X2)**

Outdoor Unit **SAP-CM1621GA**

		Indoor Unit		Outdoor Unit		Complete Unit
		Fan Motor		Fan Motor	Compressor	
Performance at		230V Single phase 50Hz				
Rating Conditions	Running Amps.	A	0.36	0.49	5.65	6.5
	Power Input	kW	0.074	0.112	1.264	1.45
Full Load Conditions	Running Amps.	A	0.36	0.49	6.85	7.7
	Power Input	kW	0.074	0.112	1.534	1.72

Rating Conditions : Indoor Air Temperature 27°C D.B. / 19°C W.B.
Outdoor Air Temperature 35°C D.B.

Full Load Conditions : Indoor Air Temperature 32°C D.B. / 23°C W.B.
Outdoor Air Temperature 43°C D.B.

Indoor Unit **SAP-K91GJA (X1)**
 Outdoor Unit **SAP-CM1821GA**

			Indoor Unit	Outdoor Unit		Complete Unit
			Fan Motor	Fan Motor	Compressor	
Performance at			230V Single phase 50Hz			
Rating Conditions	Running Amps.	A	0.18	0.49	4.13	4.8
	Power Input	kW	0.037	0.112	0.851	1.00
Full Load Conditions	Running Amps.	A	0.18	0.49	5.03	5.7
	Power Input	kW	0.037	0.112	1.041	1.19

Rating Conditions : Indoor Air Temperature 27°C D.B. / 19°C W.B.
 Outdoor Air Temperature 35°C D.B.
 Full Load Conditions : Indoor Air Temperature 32°C D.B. / 23°C W.B.
 Outdoor Air Temperature 43°C D.B.

Indoor Unit **SAP-K91GA (X2)**
 Outdoor Unit **SAP-CM1821GA**

			Indoor Unit	Outdoor Unit		Complete Unit
			Fan Motor	Fan Motor	Compressor	
Performance at			230V Single phase 50Hz			
Rating Conditions	Running Amps.	A	0.36	0.49	7.65	8.5
	Power Input	kW	0.074	0.112	1.694	1.88
Full Load Conditions	Running Amps.	A	0.36	0.49	9.95	10.8
	Power Input	kW	0.074	0.112	2.204	2.39

Rating Conditions : Indoor Air Temperature 27°C D.B. / 19°C W.B.
 Outdoor Air Temperature 35°C D.B.
 Full Load Conditions : Indoor Air Temperature 32°C D.B. / 23°C W.B.
 Outdoor Air Temperature 43°C D.B.

Indoor Unit **SAP-K91GJA (X1)**
 Outdoor Unit **SAP-CM1821JA**

			Indoor Unit	Outdoor Unit		Complete Unit
			Fan Motor	Fan Motor	Compressor	
Performance at			220V Single phase 60Hz			
Rating Conditions	Running Amps.	A	0.15	0.52	3.93	4.6
	Power Input	kW	0.031	0.114	0.815	0.96
Full Load Conditions	Running Amps.	A	0.15	0.52	4.73	5.4
	Power Input	kW	0.031	0.114	1.025	1.17

Rating Conditions : Indoor Air Temperature 27°C D.B. / 19°C W.B.
 Outdoor Air Temperature 35°C D.B.
 Full Load Conditions : Indoor Air Temperature 32°C D.B. / 23°C W.B.
 Outdoor Air Temperature 43°C D.B.

Indoor Unit **SAP-K91GA (X2)**
 Outdoor Unit **SAP-CM1821JA**

			Indoor Unit	Outdoor Unit		Complete Unit
			Fan Motor	Fan Motor	Compressor	
Performance at			220V Single phase 60Hz			
Rating Conditions	Running Amps.	A	0.30	0.52	7.68	8.5
	Power Input	kW	0.062	0.114	1.664	1.84
Full Load Conditions	Running Amps.	A	0.30	0.52	9.48	10.3
	Power Input	kW	0.062	0.114	2.064	2.24

Rating Conditions : Indoor Air Temperature 27°C D.B. / 19°C W.B.
 Outdoor Air Temperature 35°C D.B.
 Full Load Conditions : Indoor Air Temperature 32°C D.B. / 23°C W.B.
 Outdoor Air Temperature 43°C D.B.

7-2. Electric Wiring Diagram



WARNING

To avoid electrical shock hazard, be sure to disconnect power before checking, servicing and/or cleaning any electrical parts.

Indoor Unit

SAP-K91GJA

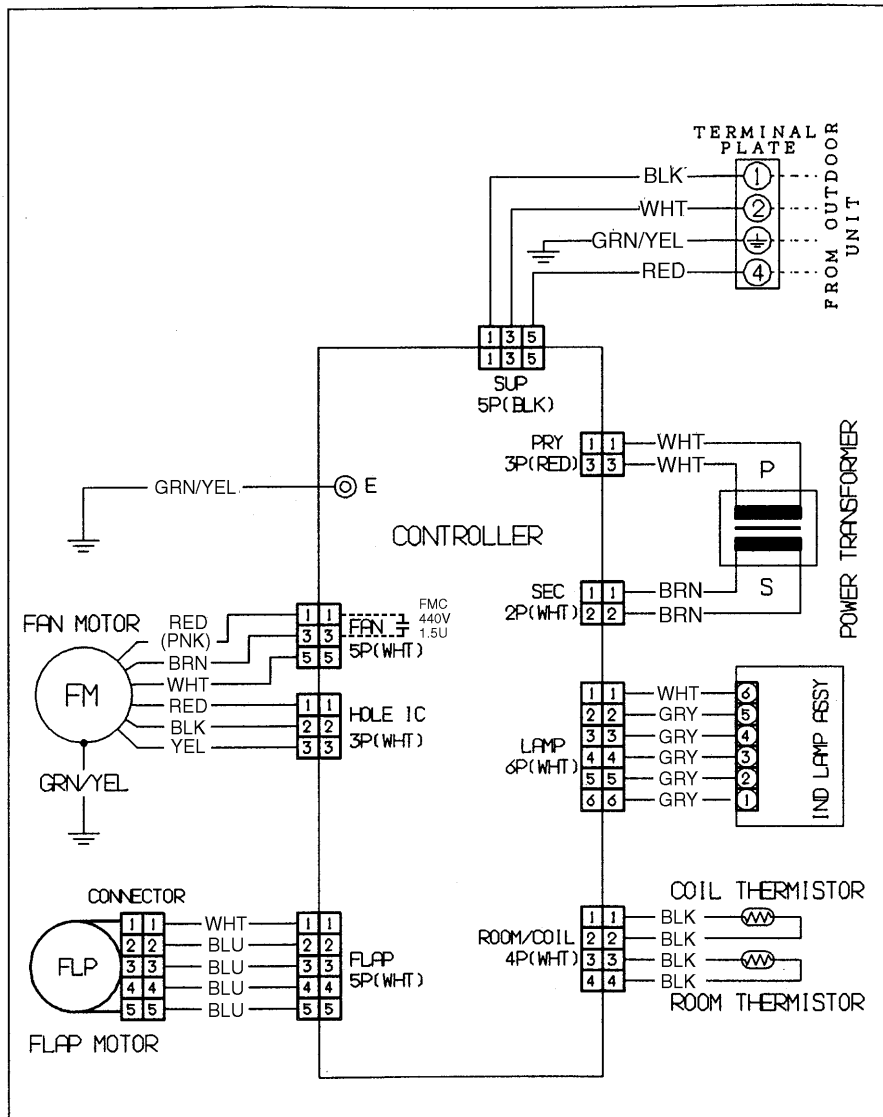

8512-5253-619xx-1

Outdoor Unit

SAP-CM1621GA
SAP-CM1821GA
SAP-CM1821JA



WARNING

To avoid electrical shock hazard, be sure to disconnect power before checking, servicing and/or cleaning any electrical parts.

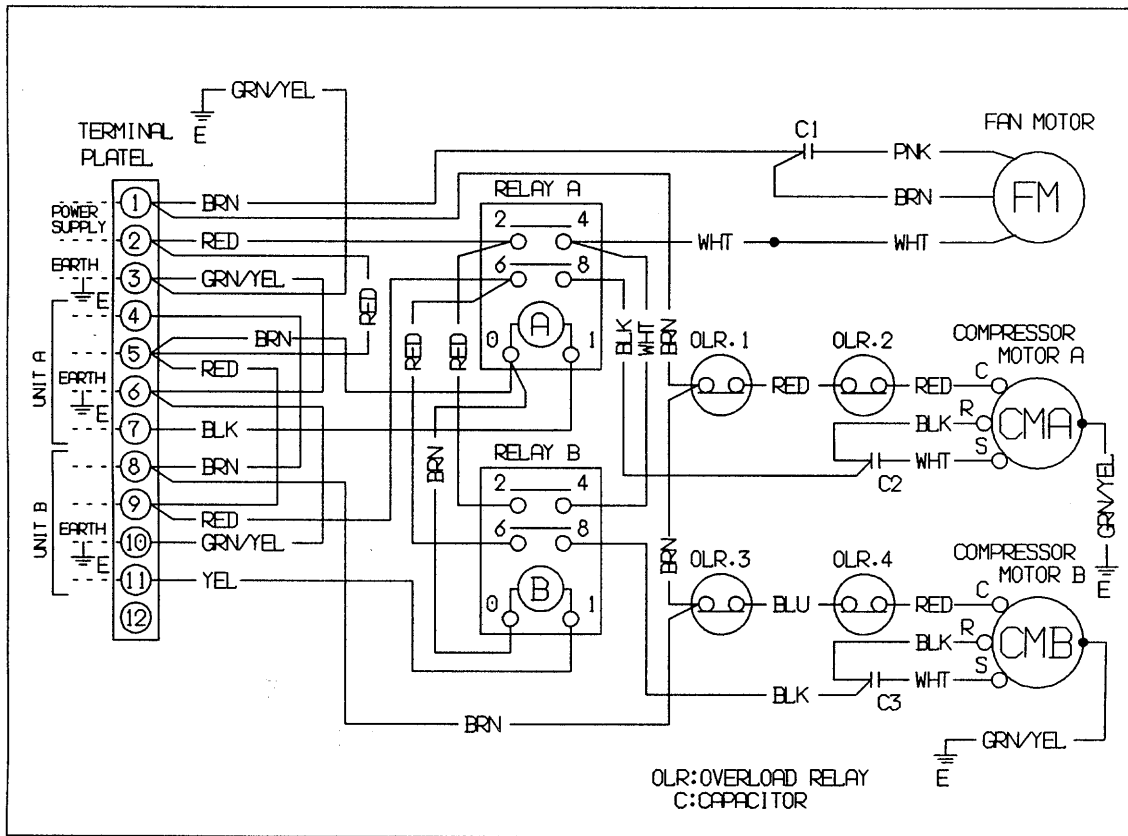

8512-5253-129xx-2

8. INSTALLATION INSTRUCTIONS

8-1. Installation Site Selection

Maximum Allowable Tubing Length(L)and Elevation Difference(H).

The Multi-Split System outdoor unit should be installed as close to the indoor units as possible. Maximum allowable length of the refrigerant tubing and elevation difference between outdoor and indoor units are shown in Table 1.

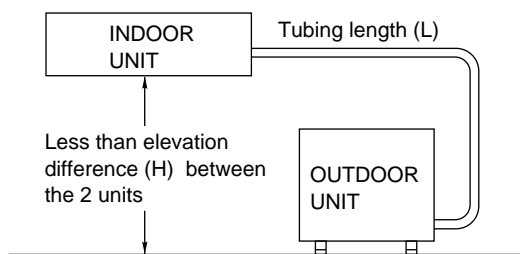

Fig. 1

Table 1

Max allowable tubing length at shipment.(m)	Limit tubing length (L). (m)	Limit of elevation difference (H). (m)	Required amount of additional refrigerant*(g/m)
7.5	15	7	15

* If total tubing length becomes 7.5 to 15 m (max.),charge additional refrigerant (R22) by 15 g/m. No additional charge of compressor oil is necessary.

Indoor Unit



WARNING

To prevent abnormal heat generation and the possibility of fire, don't place obstacles, enclosures and grilles in front of or surrounding the air conditioner in a way that may block air flow.

AVOID:

- direct sunlight.
- nearby heat sources that may affect performance of the unit.
- areas where leakage of flammable gas may be expected.
- places where large amounts of oil mist exist.

DO:

- select an appropriate position from which every corner of the room can be uniformly air-conditioned. (High on a wall is best)
- select a location that will hold the weight of the unit.
- select a location where tubing and drain pipe have the shortest run to the outside.
- allow room for operation and maintenance as well as unrestricted air flow around the unit. (Fig. 2a)

● Wall-Mounted Type

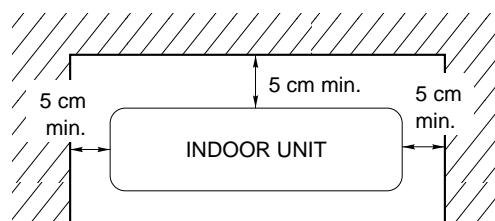

Front View

Fig.2a



CAUTION

For stable operation of the air conditioner, do not install wall-mounted type indoor units less than 1.5m from floor level.

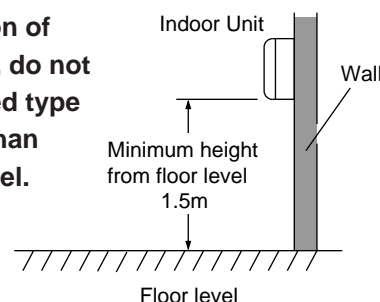

Fig. 2b

Outdoor Unit

AVOID:

- heat sources, exhaust fans, etc. (Fig. 3)
- damp, humid or uneven locations.

DO:

- choose a place as cool as possible.
- choose a place that is well ventilated.
- allow enough room around the unit for air intake/exhaust and possible maintenance.

(Figs. 4a and 4b)

- provide a solid base (concrete block, 10 × 40 cm beams or equal), a minimum of 10 cm above ground level to reduce humidity and protect the unit against possible water damage and decreased service life. (Fig. 5)
- use lug bolts or equal to bolt down unit, reducing vibration and noise.

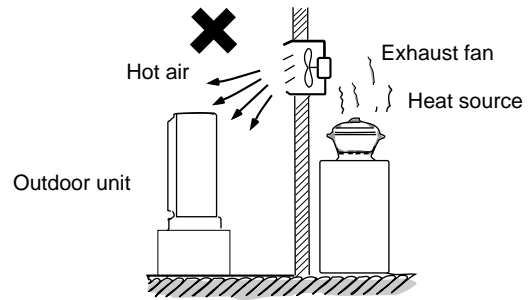

Fig. 3

Required space around the unit.

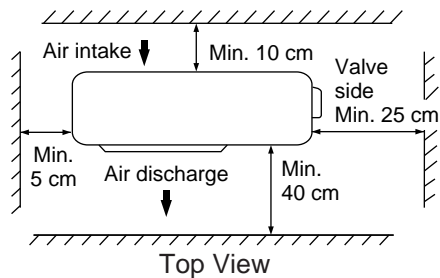
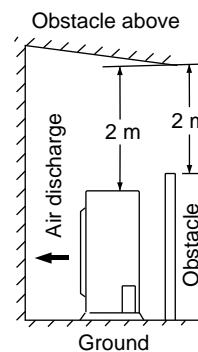

Fig. 4a



Side View

Fig. 4b

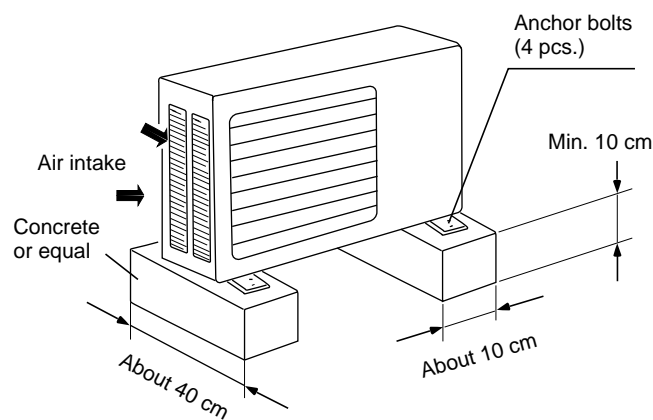

Fig. 5

7-2. Remote Control Unit Installation Position

The remote control unit can be operated from either a non-fixed position or a wall-mounted position.

To ensure that the air conditioner operates correctly, do not install the remote control unit in the following places:

- In direct sunlight
- Behind a curtain or other place where it is covered
- More than 8 m away from the air conditioner
- In the path of the air conditioner's airstream
- Where it may become extremely hot or cold
- Where it may be subject to electrical or magnetic interference

6-1. When attaching to wall (Fig.6a)

- 1) Confirm the indoor unit beeps when the ON/OFF button is pressed at the wall location where the remote control unit is to be attached, then attach the holder to the wall.
- 2) When taking out the remote control unit, pull it from the holder.

When using the remote control unit

- Point the transmission portion of the remote control unit at the receiver area of the indoor unit when operating the remote control unit, and during operation of the air conditioner.
- Do not place objects which may block the transmitted signals between the receiver and the remote control unit.

When mounting the remote control unit to prevent theft (Fig.6b)

- 1) Attach the holder to the wall with one of the screws (using only the hole in the top of the holder).
- 2) Remove the cover of the remote control unit and take out the batteries. Next, place the remote control unit in the holder.
- 3) Fasten both the remote control unit and holder to the wall with the remaining screw (using the hole in the bottom of the holder).
- 4) Install the batteries in the remote control unit and close the cover.

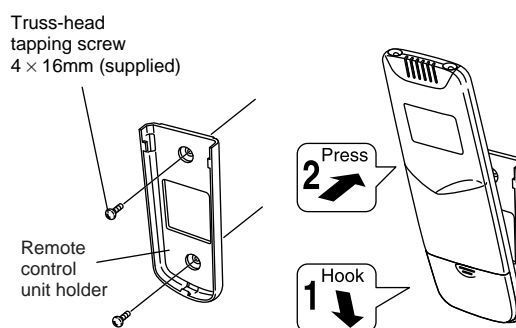

Fig.6a

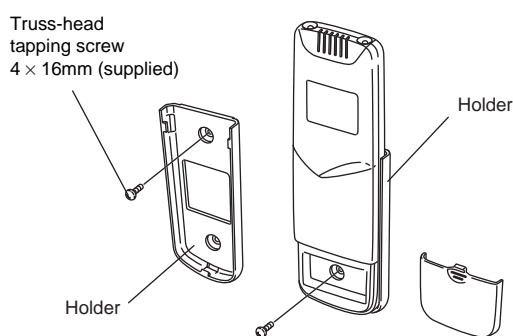

Fig.6b

8-3. Recommended Wire Length and Diameter

Regulations on wiring diameter differ from locality to locality. For field wiring requirements, please refer to your local electrical codes. Carefully observe these regulations when carrying out the installation.

Table 2 lists recommended wire lengths and size for power supply systems.

NOTE

Refer to the WIRING SYSTEM DIAGRAM for the meaning of "A" and "B" in Table 2.

Table 2

Model	Cross Sectional Area (mm ²)		(A) Power Supply Wiring Length (m)	(B) Power Line Length (m)	Fuse or Circuit Breaker Capacity
	2mm ² (#14)	3.5mm ² (#12)	2mm ² (#14)	2mm ² (#14)	
CM1621GA	24	36	20	15A	
CM1821GA, CM1821JA	18	29			

..... AWG (American Wire Gauge)



WARNING

- Be sure to comply with local codes on running the wire from the indoor unit to the outdoor unit (size of wire and wiring method, etc.).
- Each wire must be firmly connected.
- No wire should be allowed to touch refrigerant tubing, the compressor, or any moving part.

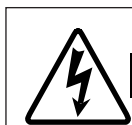

WARNING

- To avoid the risk of electric shock, each air conditioner unit must be grounded.



CAUTION

- Be sure to connect the power supply line to the outdoor unit as shown in the wiring diagram. The indoor unit draws its power from the outdoor unit.

WIRING SYSTEM DIAGRAM

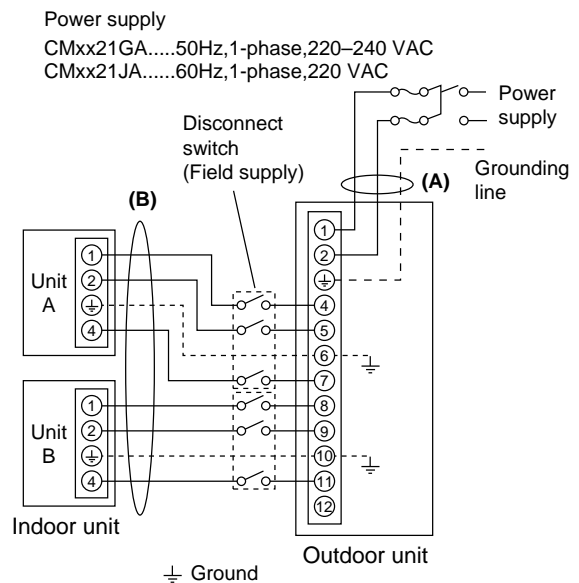

9. FUNCTION

9-1. Room Temperature Control

- Room temperature control is obtained by cycling the compressor ON and OFF under control of the room temperature sensor in the remote control unit.
- The room temperature (and other information) is transmitted every 3 minutes by the remote control unit to the controller in the indoor unit.
- The control circuit will not attempt to turn the compressor ON until the compressor has been OFF for at least 3

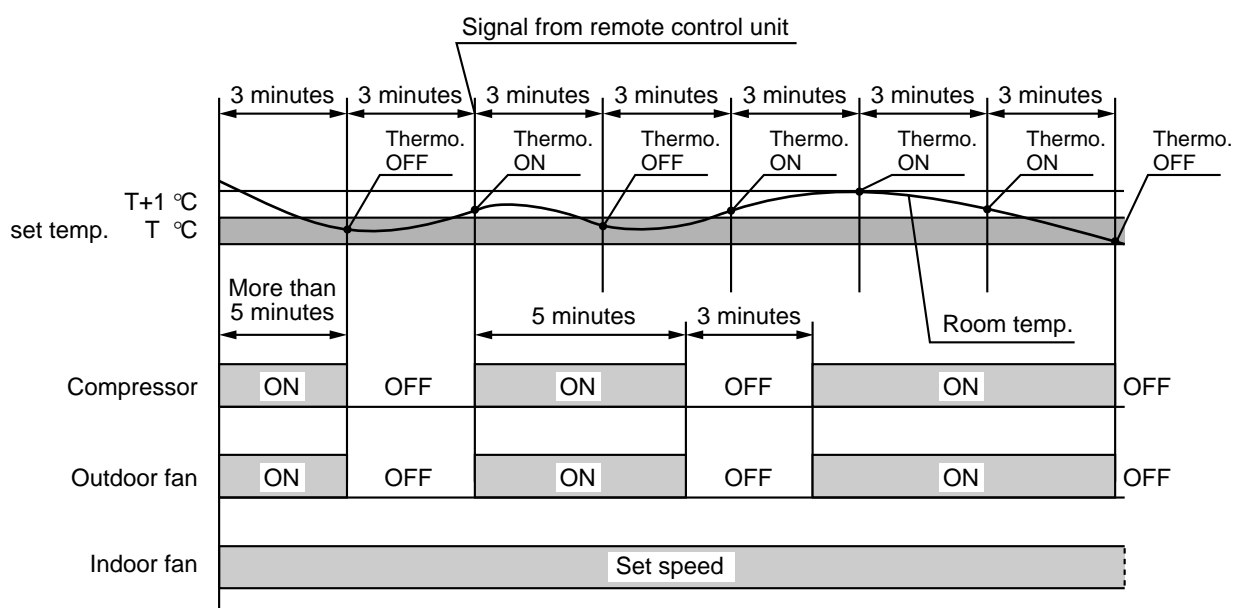

minutes. To protect the compressor from stalling out when trying to start against the high side refrigerant pressure, the control circuit has a built-in automatic time delay to allow the internal pressure to equalize.

- As a protective measure, the control circuit switches the compressor OFF after 5 minutes or more of compressor operation.
- Thermo. ON : When the room temperature is above $T + 1^{\circ}\text{C}$ ($T^{\circ}\text{C}$ is set temperature).
Compressor → ON
- Thermo. OFF : When the room temperature is equal to or below set temperature $T^{\circ}\text{C}$.
Compressor → OFF

9-2. Dry Operation (Dehumidification)

- Dry operation uses the ability of the cooling cycle to remove moisture from the air, but by running at low level to dehumidify without greatly reducing the room temperature. The air conditioner repeats the cycle of turning ON and OFF automatically as shown in the chart below according to the room temperature.

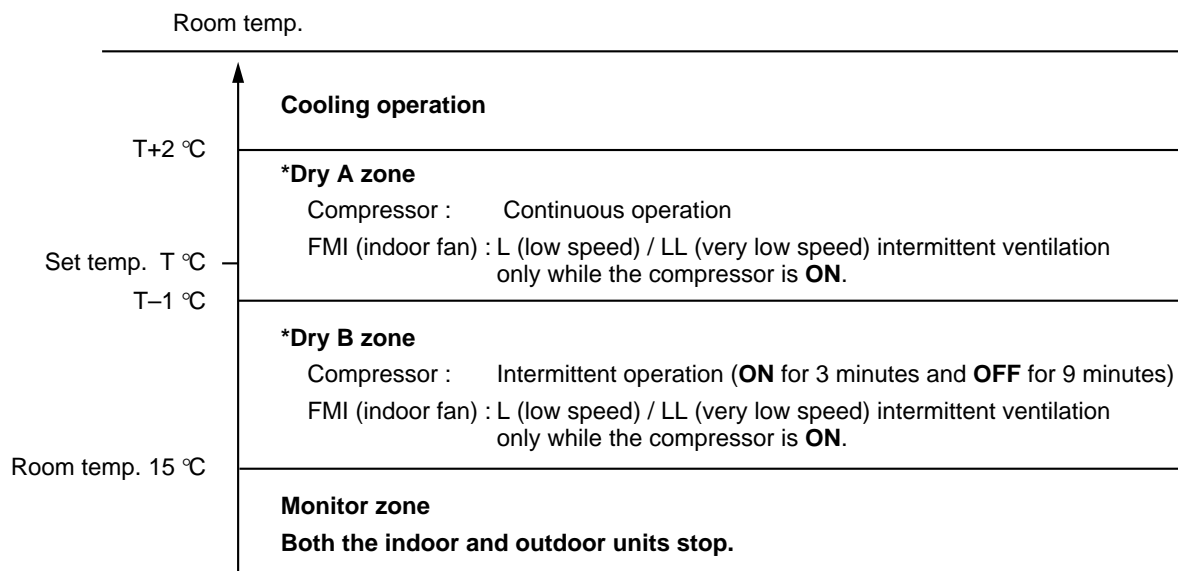

NOTE

- Intermittent ventilation occurs by switching the indoor fan speed between L ↔ LL.
- Dry operation does not occur when the room temperature is under 15°C, which is the monitor zone.
- When the compressor stops, the indoor fan stops as well.

9-3. Freeze Prevention

- This function prevents freezing of the indoor heat exchange coil.
- When the compressor has been running for 10 minutes or more and the temperature of the indoor heat exchange coil falls below -1°C, the control circuit stops the compressor for at least 6 minutes. The compressor does not start again until the temperature rises above 8°C or 6 minutes has elapsed.

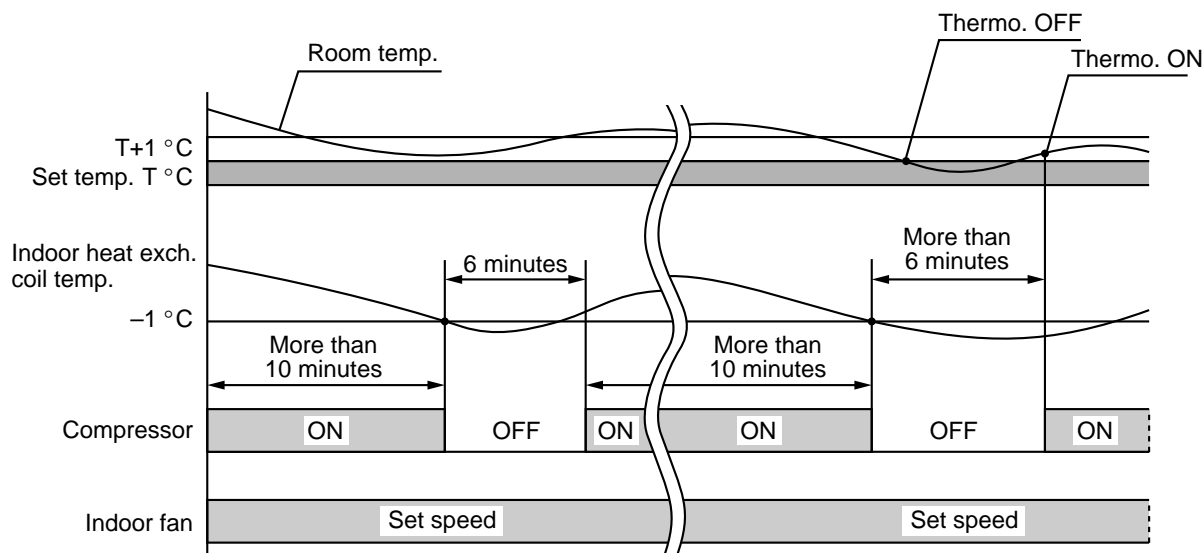

10. TROUBLESHOOTING

10-1. Check before and after troubleshooting



WARNING

Hazardous voltage can cause **ELECTRIC SHOCK** or **DEATH**. Disconnect power or turn off circuit breaker before you start checking or servicing.

10-1-1. Check power supply wiring.

- Check that power supply wires are correctly connected to terminals **No.1** and **No.2** on the terminal plate in the outdoor unit.

10-1-2. Check inter-unit wiring.

- Check that inter-unit wiring is correctly connected to the indoor unit from the outdoor unit.

10-1-3. Check power supply.

- Check that voltage is in specified range ($\pm 10\%$ of the rating).
- Check that power is being supplied.

10-1-4. Check lead wires and connectors in indoor and outdoor units.

- Check that coating of lead wires is not damaged.
- Check that lead wires and connectors are firmly connected.
- Check that wiring is correct.

Power supply
CMxx21GA.....50Hz, 1-phase, 220–240 VAC
CMxx21JA.....60Hz, 1-phase, 220 VAC

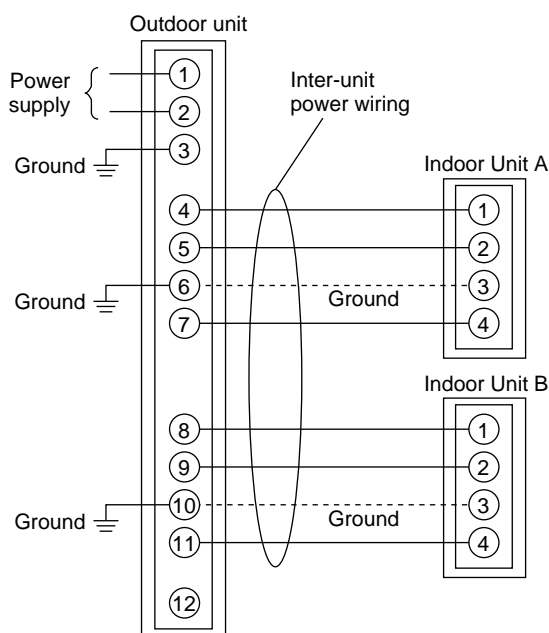

10-2. Air conditioner does not operate.

10-2-1. Circuit breaker trips (or fuse blows).

A. When the circuit breaker is set to ON, it is tripped soon. (Resetting is not possible.)

- There is a possibility of ground fault.
- Check insulation resistance.

If resistance value is $2M\Omega$ or less, insulation is defective ("NO").

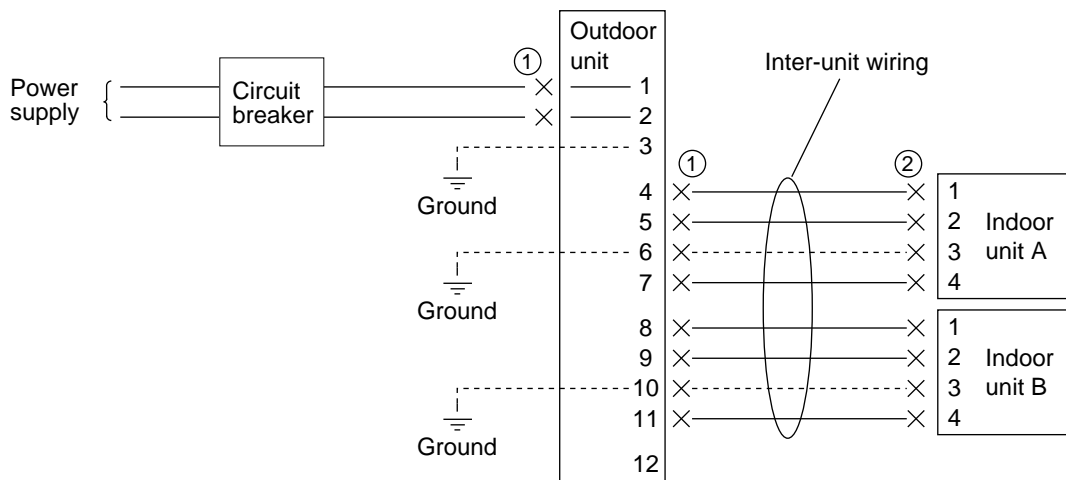

WARNING

* Set circuit breaker to OFF.

- ① Remove both power supply wires and inter-unit wires from terminal plate in outdoor unit.
- Measure insulation resistance of outdoor unit.

NO

Insulation of outdoor unit is defective.

- Measure insulation resistance of electrical parts in outdoor unit.

- ② Remove inter-unit wires from terminal plate in indoor unit.
- Measure insulation resistance of indoor unit.

NO

Insulation of indoor unit is defective.

- Measure insulation resistance of electrical parts in indoor unit.

B.Circuit breaker trips in several minutes after turning the air conditioner on.

- There is a possibility of short circuit.

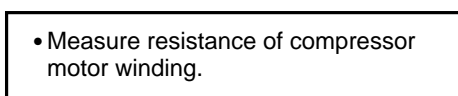
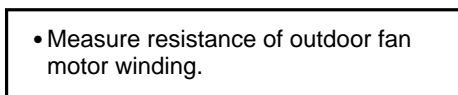
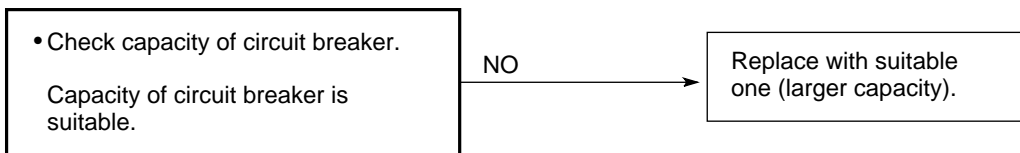

10-2-2. Neither indoor nor outdoor unit runs.

A. Power is not supplied.

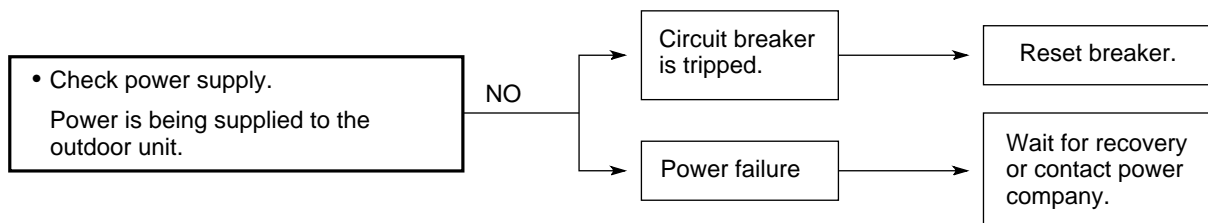

B. Check remote control unit.

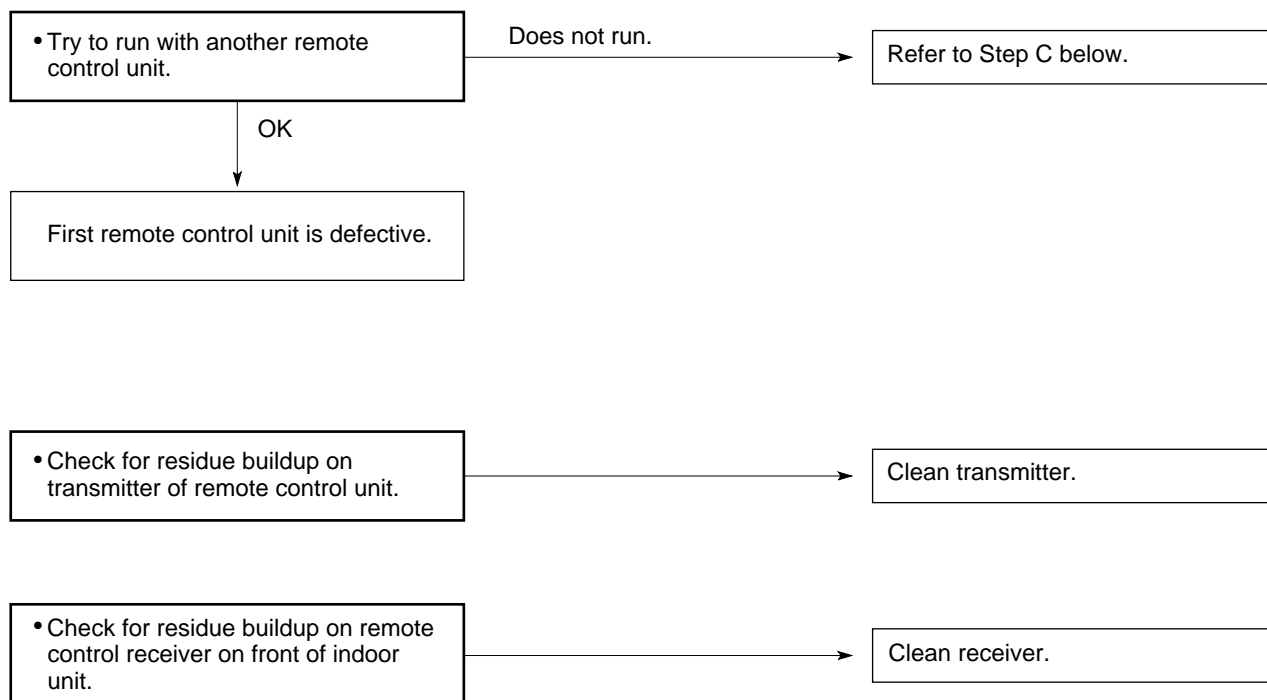

C. Check "OPERATION selector" switch in the indoor unit.

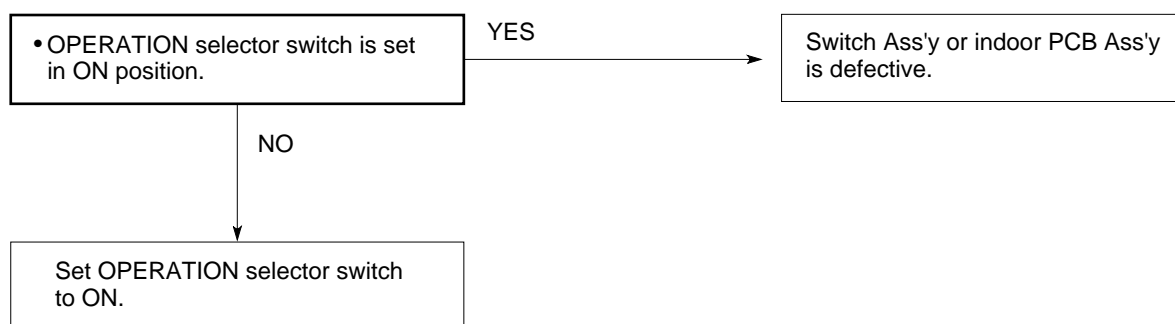

D. Check transformer in indoor unit.

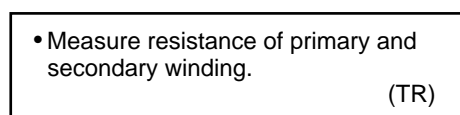

E. Check fuse on the indoor PCB Ass'y.

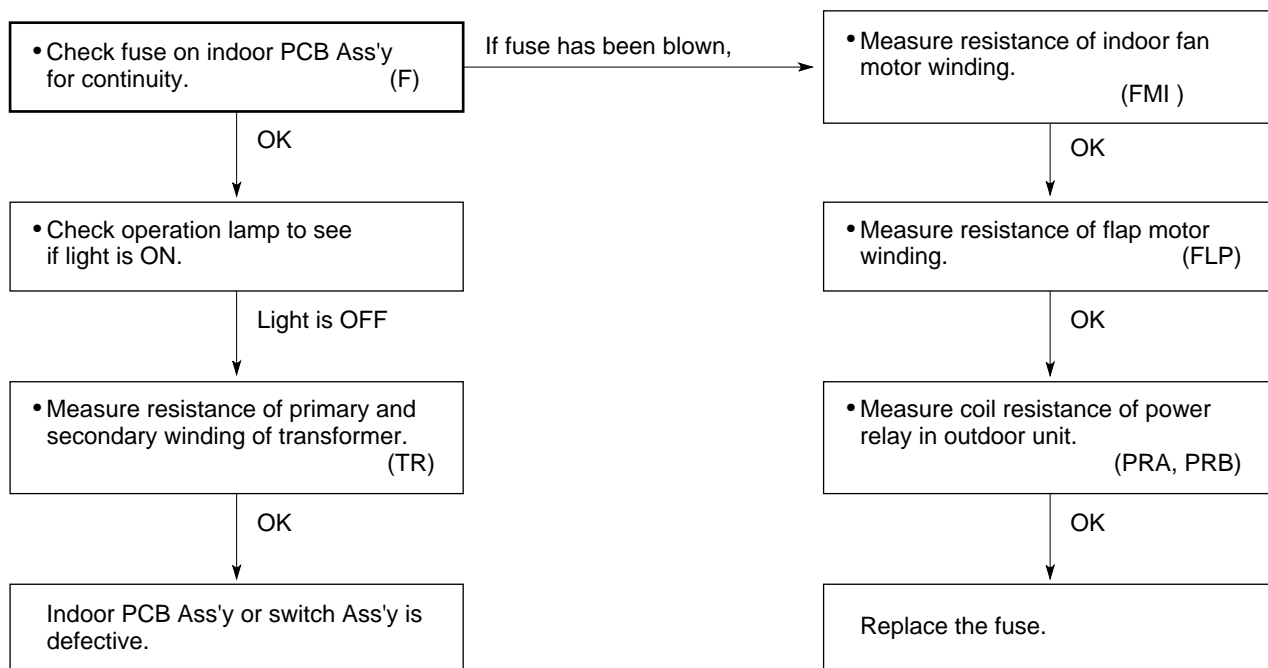

F. Check TIMER on the remote control unit.



10-2-3. Only outdoor unit does not run.

A. Check setting temperature.

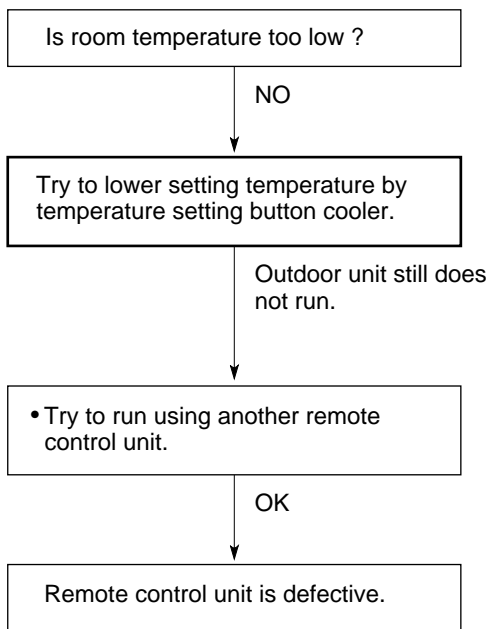

B. Check power relay in outdoor unit.

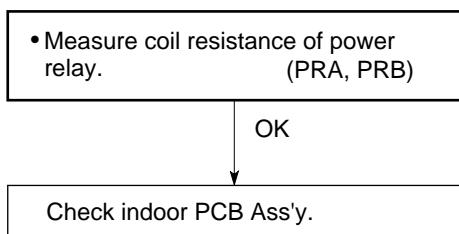

10-3. Some part of air conditioner does not operate.

10-3-1. Only indoor fan does not run.

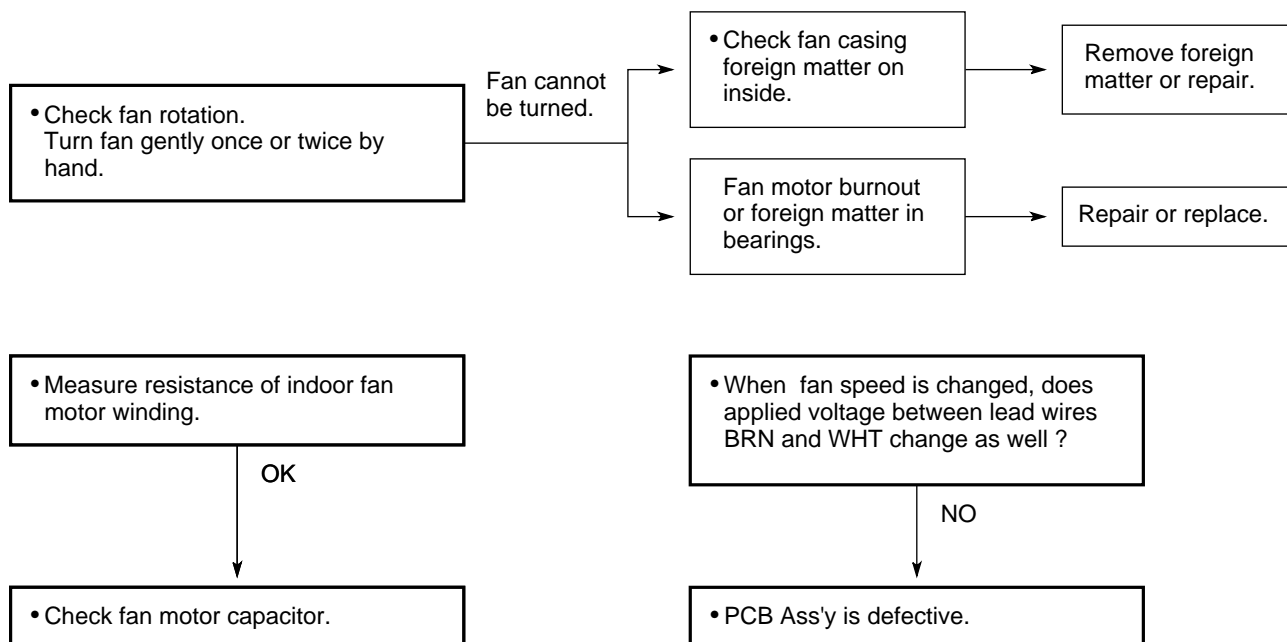

10-3-2. Only outdoor fan does not run.

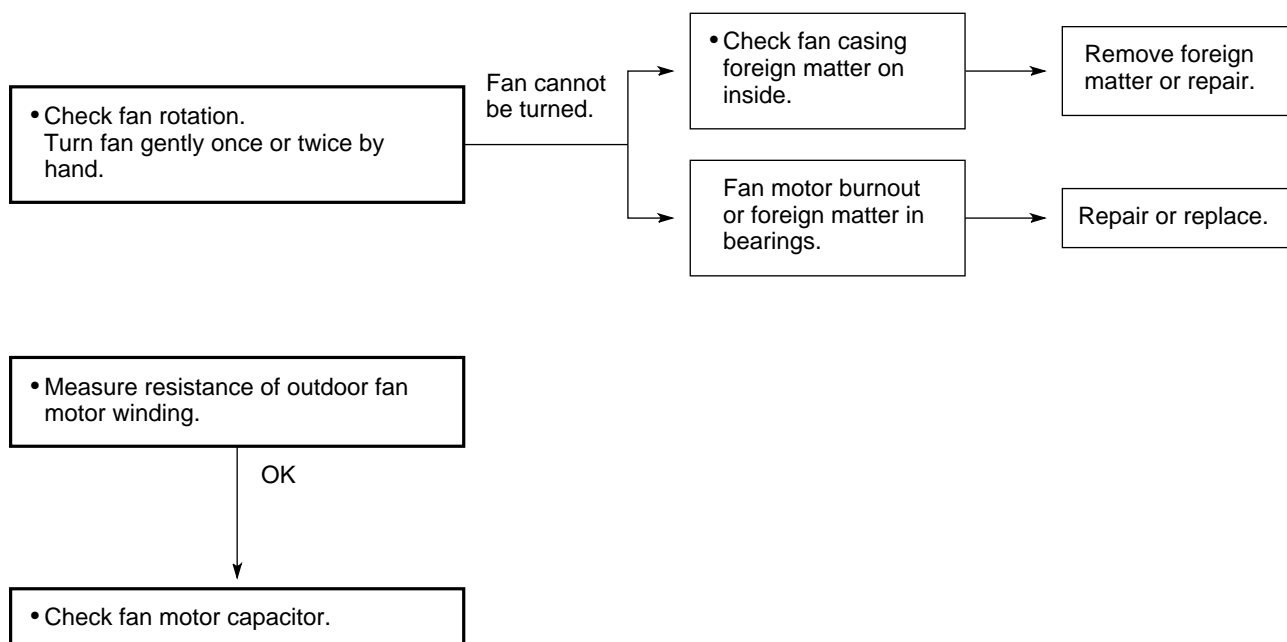

10-3-3. Only compressor does not run.

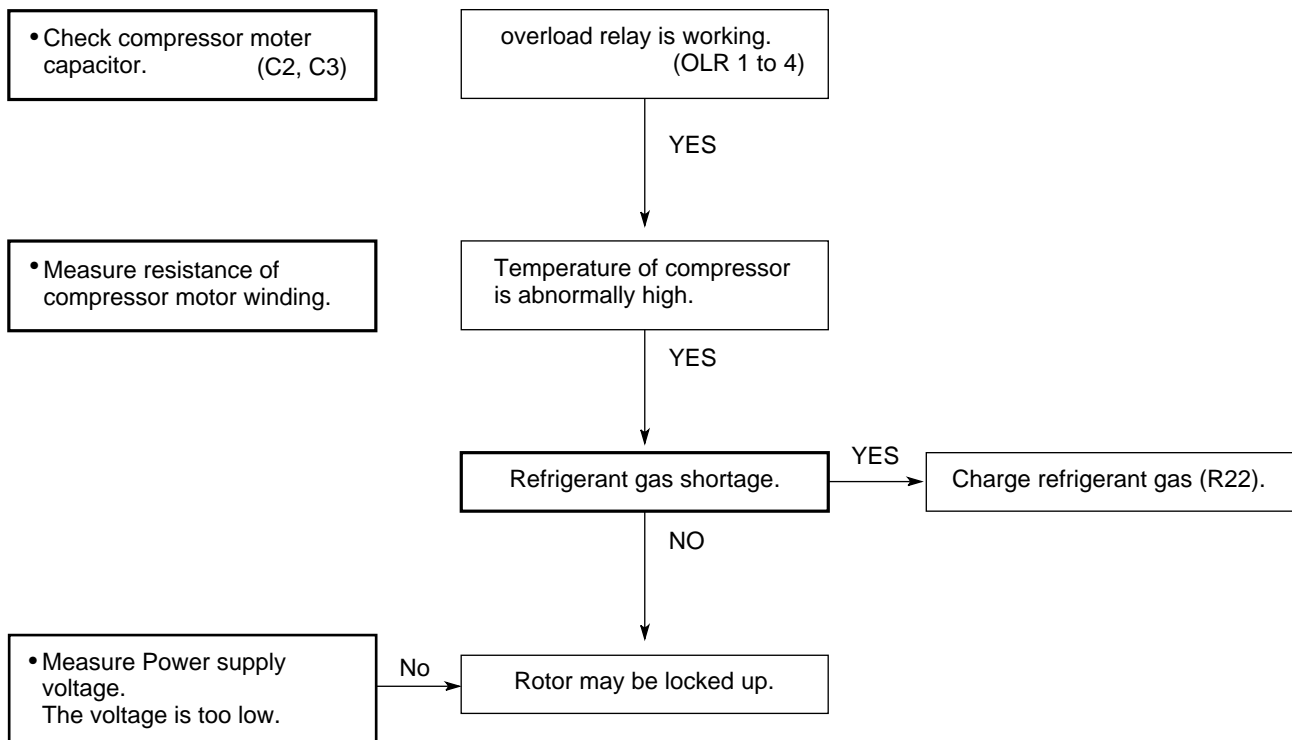

10-3-4. Only flap motor does not run.

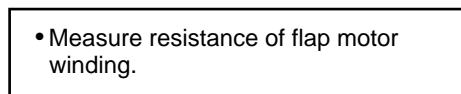

10-4. Air conditioner operates, but abnormalities are observed.

10-4-1. Poor cooling.

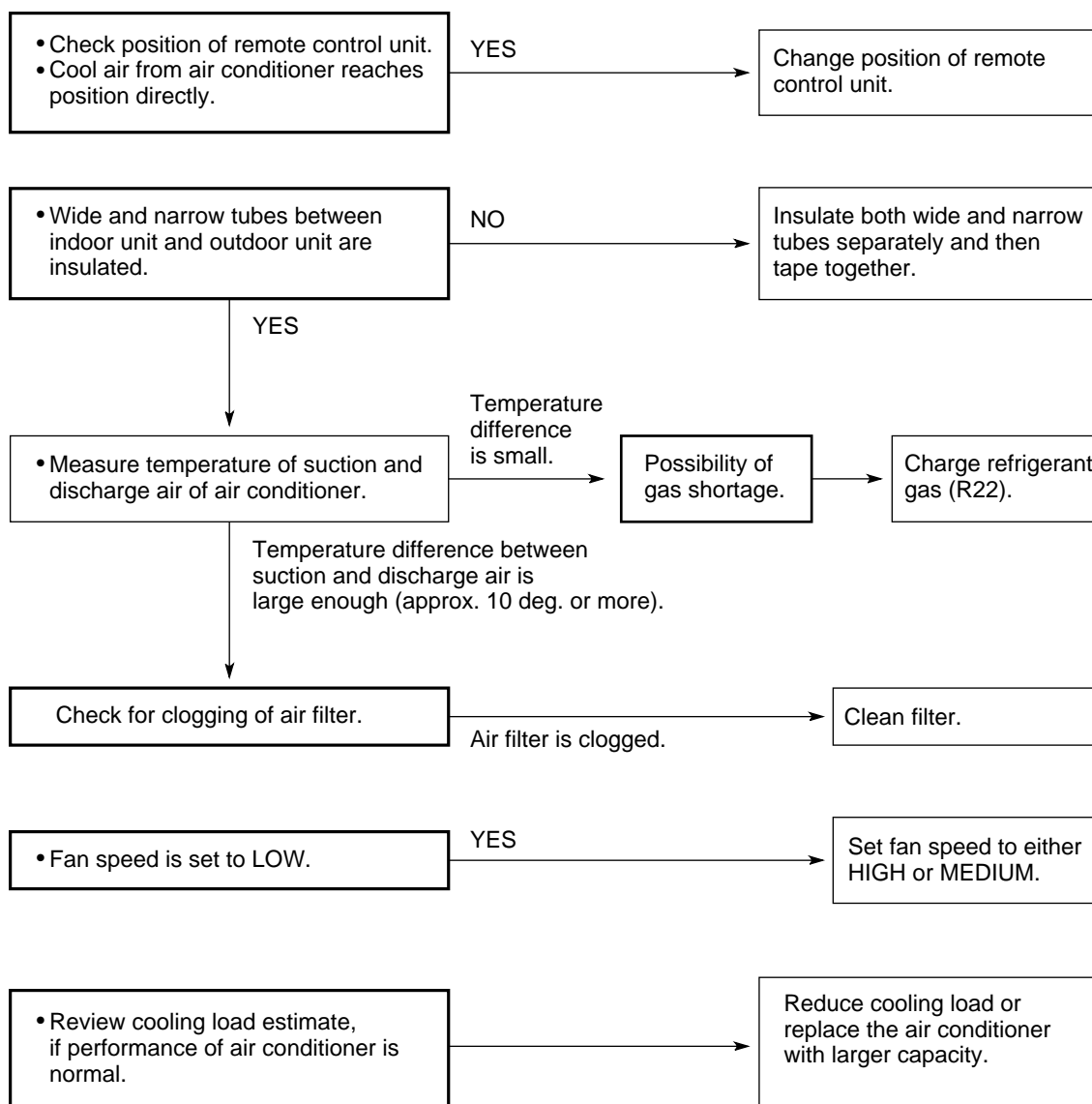

10-4-2. Excessive cooling.

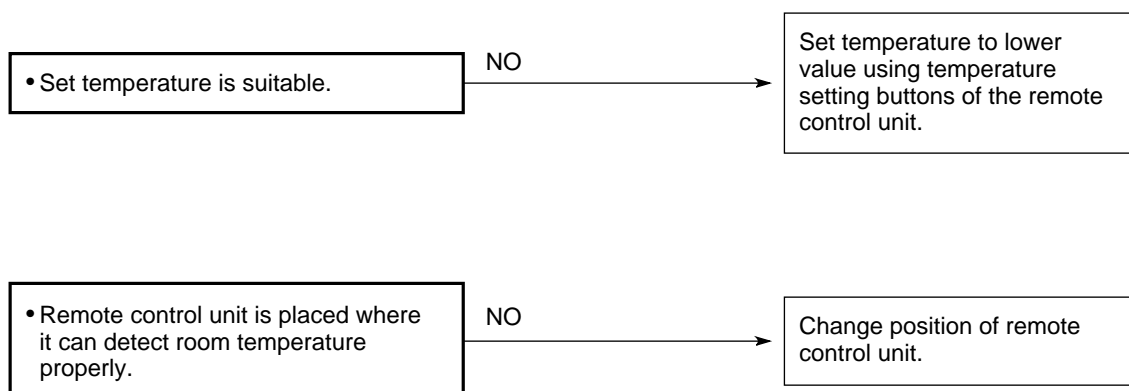

10-5. If a sensor is defective.

10-5-1. Indoor coil temp. thermistor (TH1) is defective.

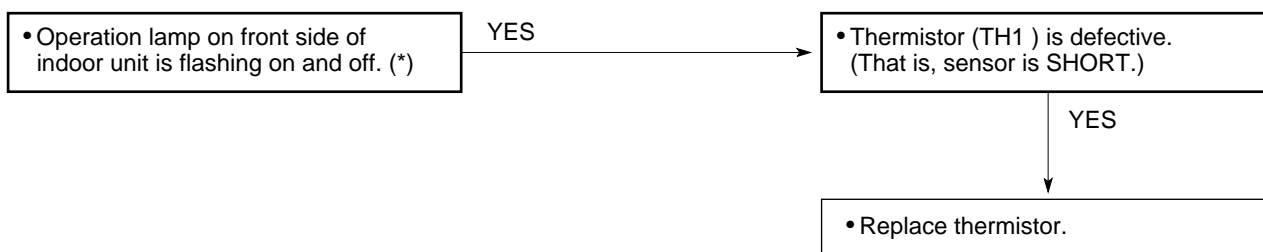

NOTE Alarm Signal (*)

Operation lamp on the front side of the indoor unit will flash on and off when the indoor coil thermistor is defective. At the same time the outdoor unit will stop. Indoor unit will operate only for ventilation.

10-5-2. Room temp. thermistor (TH2) is defective.

A. Open

When thermistor opens, the air conditioner will be in the following conditions as the controller tries to detect extremely low room temperature.

In Cooling mode : The air conditioner soon stops and will not start again. (Thermo.OFF)
Neither outdoor fan nor compressor runs.

B. Short

When thermistor is short, the air conditioner will be in the following conditions as the controller tries to detect extremely high room temperature.

In Cooling mode : The air conditioner continues to operate. (Thermo.ON) Both the outdoor fan and compressor do not stop.
As a result, the room becomes too cold.

NOTE Definition of Open or Short Circuit of Sensor (Thermistor)

Open... A lead wire is broken or disconnected or the circuit inside the temperature sensor is open .

Short... The protective cover of a lead wire has been damaged, and the exposed wire is touching another metal part, or both lead wires have become exposed and are touching each other. Alternatively, the circuit inside the temperature sensor is closed.

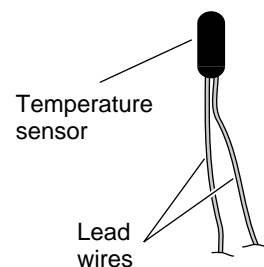

Thermistor Structure

11. ARRANGEMENT OF ELECTRICAL COMPONENT

Outdoor Unit **SAP-CM1621GA**
 SAP-CM1821GA
 SAP-CM1821JA

● Electric Parts

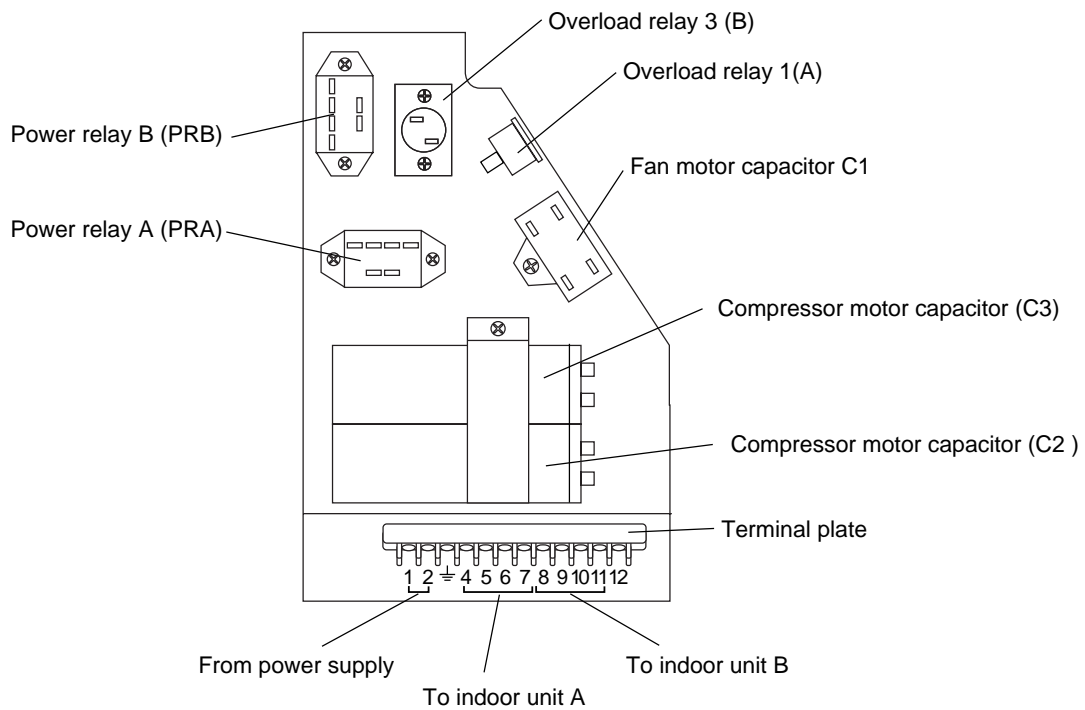

● Parts Layout in Unit

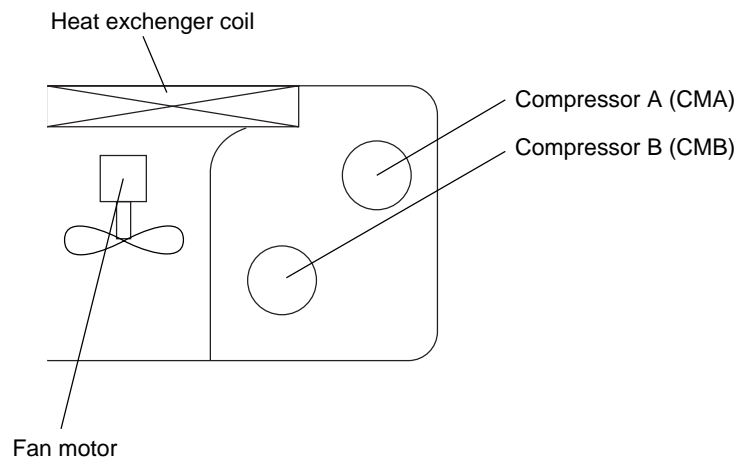

12. CHECKING ELECTRICAL COMPONENTS

12-1. Measurement of Insulation Resistance

- The insulation is in good condition if the resistance exceeds $2M\Omega$.

12-1-1. Power Supply Wires

Clamp the ground wire of the power supply wires with the lead clip of the insulation resistance tester and measure the resistance by placing a probe on either of the power wires. (Fig. 1)

Then measure the resistance between the ground wire and the other power wire. (Fig. 1)

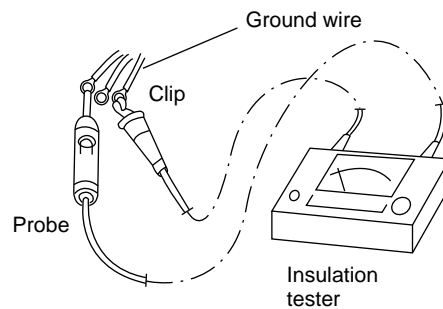

Fig. 1

12-1-2. Indoor Unit

Clamp an aluminum plate fin or copper tube with the lead clip of the insulation resistance tester and measure the resistance by placing a probe on each terminal screw on the terminal plate. (Fig. 2)

Note that the ground line terminal should be skipped for the check. (Fig. 2)

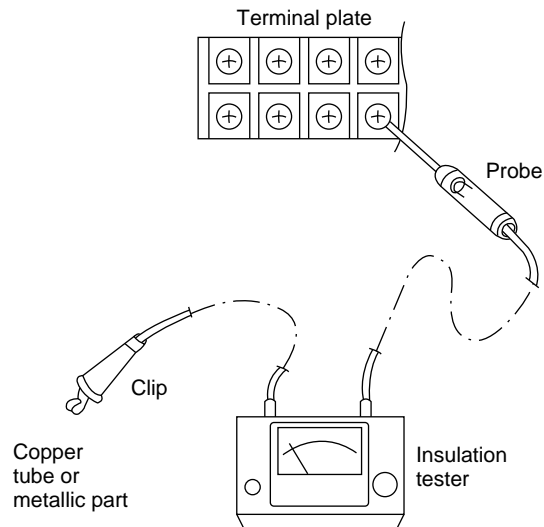

Fig. 2

12-1-3. Outdoor Unit

Clamp a metallic part of the unit with the lead clip of the insulation resistance tester and measure the resistance by placing a probe on each terminal screw where power supply lines are connected on the terminal plate. (Fig. 2)

12-1-4. Measurement of Insulation Resistance for Electrical Parts

Disconnect the lead wires of the desired electric part from terminal plate, capacitor, etc. Similarly disconnect the connector. Then measure the insulation resistance. (Figs. 3 and 4)

Refer to Electric Wiring Diagram.

NOTE

If the probe cannot enter the poles because the hole is too narrow then use a probe with a thinner pin.

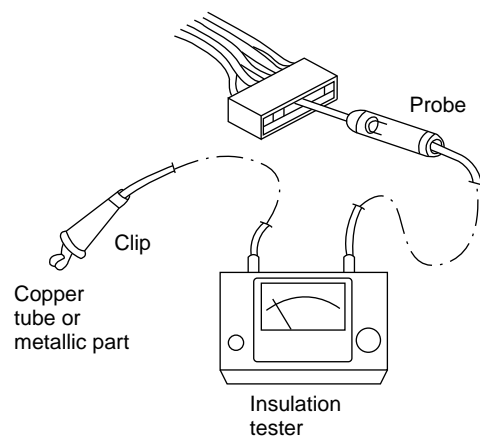

Fig. 3

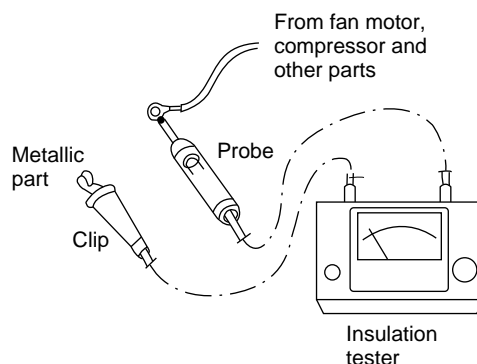

Fig. 4

12-2. Checking Continuity of Fuse on PCB Ass'y

- Remove the PCB Ass'y from the electrical component box. Then pull out the fuse from the PCB Ass'y.
- Check for continuity using a multimeter as shown in Fig. 6.

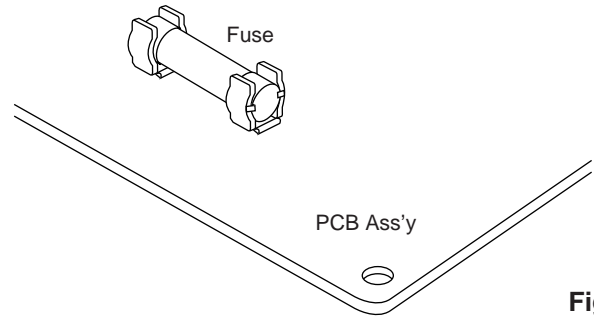

Fig. 5

12-3. Checking Motor Capacitor

Remove the lead wires from the capacitor terminals, and then place a probe on the capacitor terminals as shown in Fig. 7. Observe the deflection of the pointer, setting the resistance measuring range of the multimeter to the maximum value.

The capacitor is “good” if the pointer bounces to a great extent and then gradually returns to its original position.

The range of deflection and deflection time differ according to the capacity of the capacitor.

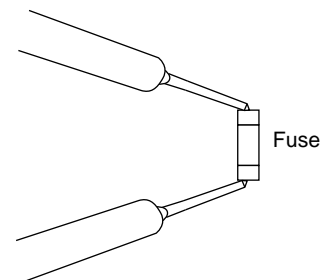

Fig. 6

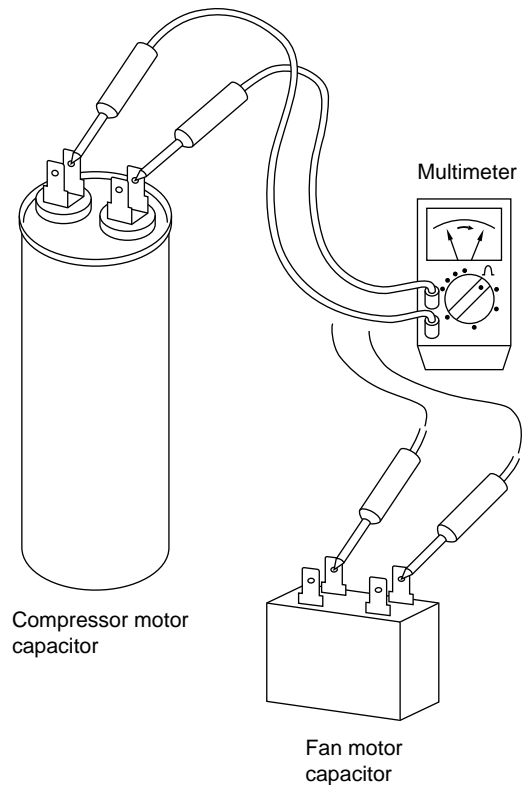

Fig. 7



SANYO

SANYO Electric Co.,Ltd.

Osaka, Japan

SM700468 11/00/200

Printed in Japan

Большая библиотека технической документации

<https://splitsystema48.ru/instrukcii-po-ekspluatácii-kondicionerov.html>

каталоги, инструкции, сервисные мануалы, схемы.